

MOBILE POWER

Product Selector Guide



Table of Contents

Introduction3

Power Management ICs (PMICs).....3

High-Performance Smartphone PMIC4

Single-Cell Power Supply for Wireless Hearables5

Single-Cell Lithium-Ion Battery-Operated
Systems with Display7

Single-Cell Power Management for Portable Music
Players8

Smart Power Selector Convenient Charging9

Battery Chargers and Fuel Gauges11

Li+ Battery Charge Termination11

Single-Cell Battery Charger for Handheld
Gaming Devices12

Linear vs. Switch-Mode Charging12

Wireless Sensor Battery Charger.....13

Single-Cell Digital Camera Battery Charger13

Integrated Battery Charger and Fuel Gauge14

Single-Cell Wireless Speaker Charger and Fuel Gauge...15

Fuel Gauges and the ModelGauge m5 Algorithm17

Featured Technology: EZ Config.....17

MAX17055 High-Accuracy Fuel Gauge.....18

Counterfeit Battery Prevention with
SHA-256 Fuel Gauge Authentication.....19

Low-Power Fuel Gauge for Wireless Sensors.....21

Multi-Cell Fuel Gauge for Robots and Drones22

DC-DC Converters24

Remote Sense Enhances Regulation and
Load Transient Response.....25

Voltage Positioning Increases Load
Transient Immunity26

USB Type-C Port Controller Power Supply27

Improve Boost Efficiency in Battery
Applications with Auto-Track.....28

Increase Battery Life with True Shutdown29

High-Efficiency Buck-Boost Regulator30

LED Drivers33

LED Driver Topologies.....34

Transmissive LCD LED Backlight Driver35

Single WLED Camera Flash Driver36

LED Ambient Temperature Derating
Protection.....37

Dual-Phase Step-Up Converter and LED Driver38

List of Figures40

Related Resources42

Trademarks42

List of Tables

Table 1. Power Management IC Product Selector10

Table 2. Battery Charger Product Selector.....16

Table 3. Fuel Gauges with SHA-256 Authentication19

Table 4. ModelGauge Fuel Gauge Product Selector23

Table 5. Buck Converter—Remote Sensing
and Voltage Positioning Product Selector31

Table 6. Boost Converter Product Selector32

Table 7. Buck-Boost Converter Product Selector32

Table 8. LED Driver Product Selector39

Introduction

This edition of the Mobile Power Product Selector Guide highlights our most popular power solutions for battery-powered devices. You'll find insights to key features that enable longer battery life and reduced system size for mobile devices, including the advantages they deliver for battery-operated systems. Several applications are highlighted to demonstrate the benefits of these features. At Maxim, we are committed to providing the technology you need to empower design innovation for your mobile system designs.

Power Management ICs (PMICs)

High-performance mobile devices employ a variety of processors and/or FPGAs to perform target applications. These systems are typically battery-operated and require multiple low-voltage rails and protection. They may also include application-specific features. PMICs (*Figure 1*) offer highly integrated solutions for modern high-performance

mobile systems. PMIC solutions may include DC-DC converters, LDOs, battery chargers, fuel gauges, LED drivers and a variety of additional features that allow for monitoring and control of system performance. These highly integrated solutions provide the high performance and small size demanded by mobile applications, all with high efficiencies to maximize battery life.

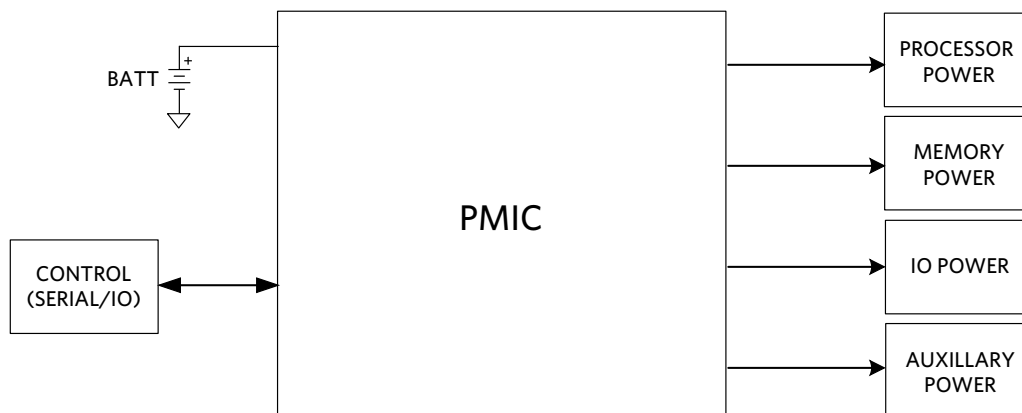

Figure 1. Typical CPU Power Rails Provided by a PMIC

High-Performance Smartphone PMIC

Smartphones require multiple voltage rails that support aggressive load transients to power high-end processors. High efficiency and small size are necessary characteristics for DC-DC converters in this application. The **MAX8660** PMIC (Figure 2) supplies a total of eight voltage rails designed for high-performance compact systems. Two dynamically controlled step-down converters allow for in-system dynamic voltage management (DVM) to optimize system performance during normal operation. Monitoring and control are provided via I²C serial communication for effective software management. Additional features include hardware ON/OFF output voltage control, low-battery indicator, and reset output. Altogether, these features provide a high-performance system in a 40-pin TQFN package.

Key Features of MAX8660

- Configurable Power Performance
 - Four Step-Down DC-DC Converters
 - Four LDO Regulators
 - Adjustable Soft-Start Ramp-Rate
 - Power Sequencing
 - I²C Serial Interface
- Small Solution Size
 - 2MHz Switching Frequency Allows for Small Components
 - 40-Pin TQFN Package
- Extends Battery Life
 - 20µA Deep-Sleep Current
 - Automatic Switching Between FPWM and Light-Load Operation
- Integrated Protection
 - Thermal Overload Protection
 - Input Under/Overvoltage Lockout
 - Internal Off-Discharge Resistors

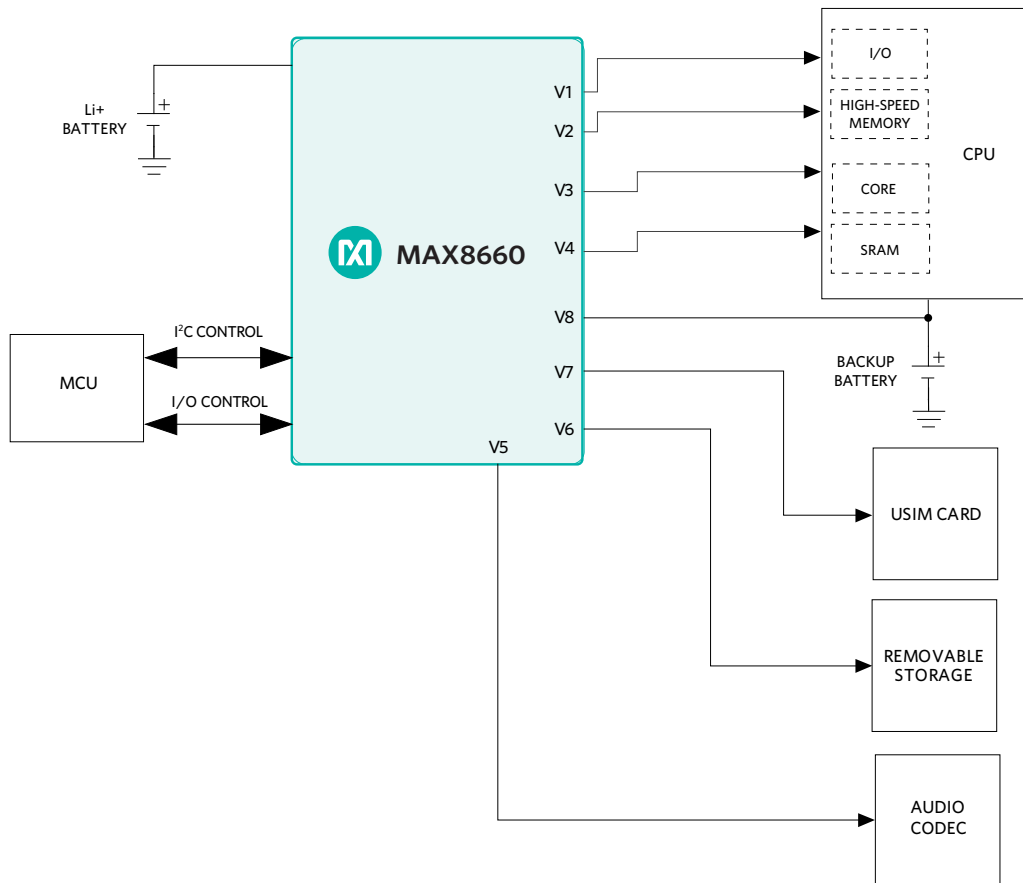

Figure 2. Smartphone Block Diagram Using MAX8660 PMIC

Single-Cell Power Supply for Wireless Hearables

Hearable devices have evolved from simple headsets (speakers and microphones) with wired analog connectors to highly integrated audio systems capable of wirelessly transmitting and receiving digital audio data. This evolution has allowed systems to eliminate the need for wired audio connectors, such as the iconic 3.5mm jack, in favor of wireless communication using Bluetooth®. Additionally, an in-system audio digital signal processor (DSP) enhances the overall listening experience, and is paired with captive speaker loads that enable efficient, low-noise amplifier technologies.

Wireless hearable form-factors place size limitations on both system design and battery selection, and thus small-scale PMICs are required to provide system power from a battery source with high efficiency and low quiescent current.

The **MAX77650** SIMO buck-boost PMIC features low-quiescent power consumption and minimizes the solution size by efficiently providing a total of 3 DC outputs using a single inductor. This compact PMIC provides the multiple rails that are required by modern headphone applications utilizing both tethered and untethered system architectures. Tethered headphones use a physical connection between the left and right speakers, while untethered headphones use a wireless link between the left and right speakers. Therefore, untethered headphones require independent supplies for both the right and left speakers. **Figures 3** and **4** demonstrate application systems for wireless hearables using the MAX77650 PMIC, the **MAX17048** fuel gauge and the **MAX98090** low-power high-performance CODEC. For size-constrained applications, the **MAX9867** CODEC is recommended.

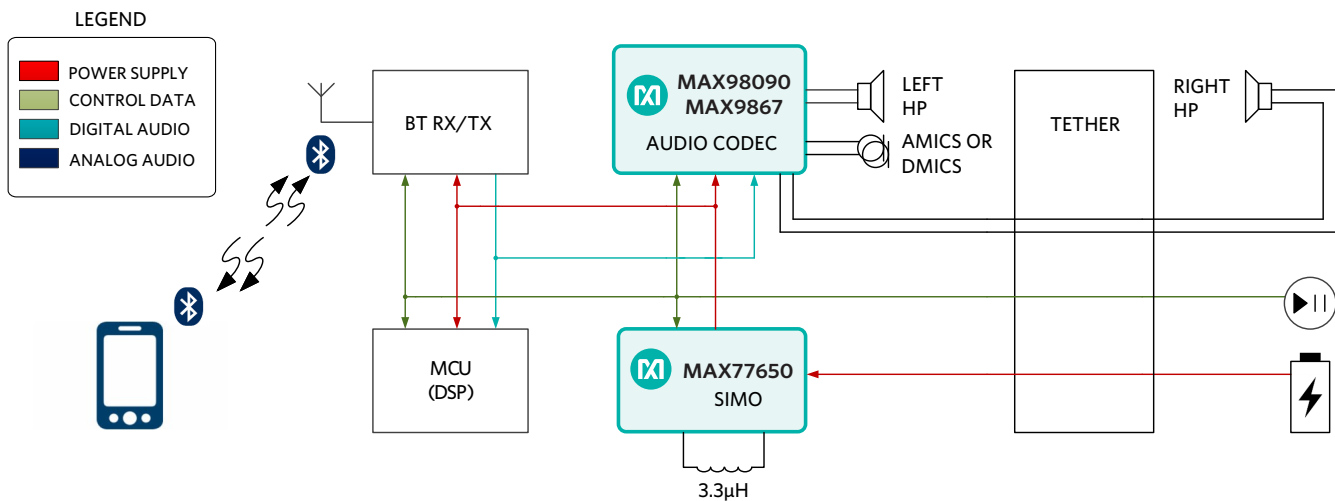

Figure 3. Tethered Bluetooth Headset Application Using the MAX77650 SIMO

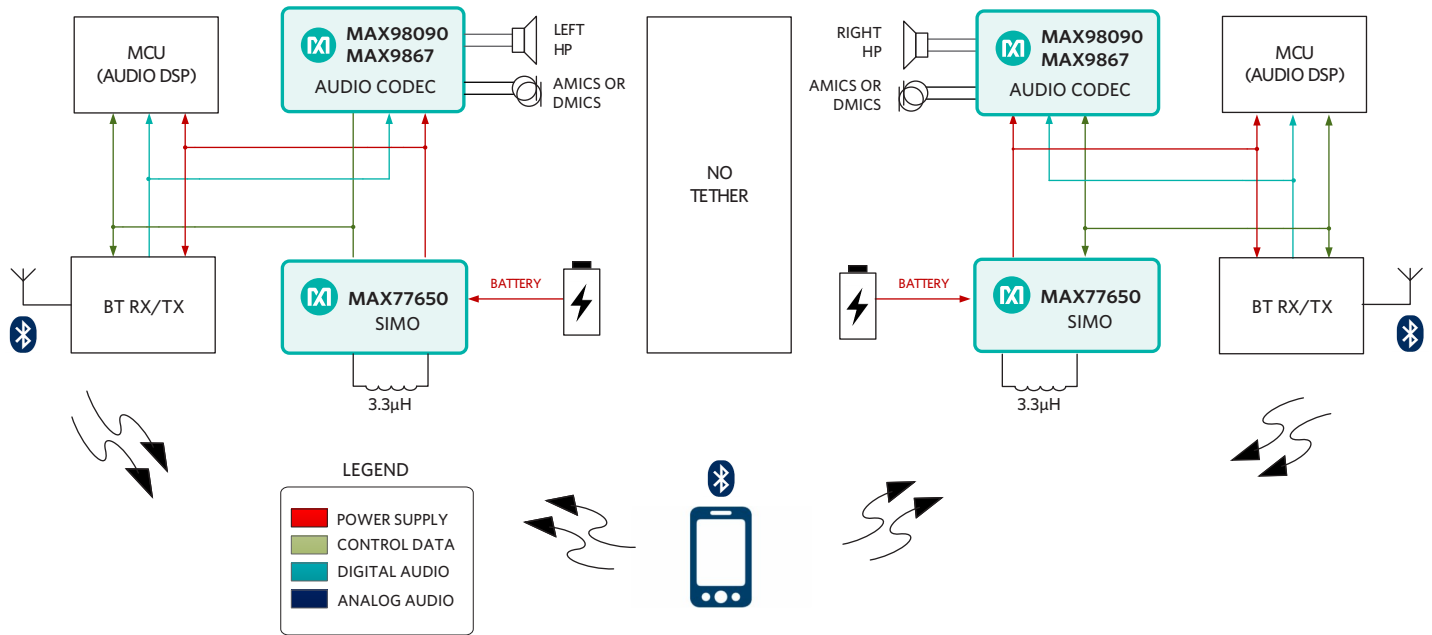

Figure 4. Untethered Bluetooth Headset Application Using MAX77650 SIMO

Single-Cell Lithium-Ion Battery-Operated Systems with Display

The small size of battery-operated devices requires a high level of integration to fit all the required functions into the limited space available. These systems typically require battery charging and several voltage rails. The **MAX8662** PMIC (*Figure 5*) provides seven voltage rails and a single-cell lithium-ion (Li+) battery charger for small-scale portable systems. The integrated battery charger uses proprietary Smart Power Selector™ technology to automatically distribute power between the source, battery, and system without the need for external switches. Backlighting typically required by mobile displays is regulated using a 30mA white LED driver with versatile PWM and analog dimming control. Integrated protection features increase system reliability using only a few external components.

Key Features of MAX8662

- Two 95% Efficient Buck Regulators
- Four Low-Dropout Linear Regulators
- White LED Driver
 - 30mA (max)
 - PWM and Analog Dimming Control
- Adaptive Battery Charger
 - Smart Power Selector
- Integrated Protection
 - IC Thermal-Overload Protection
 - NTC Thermistor Input
 - Input Under/Overvoltage Lockout
 - Input Overcurrent Protection

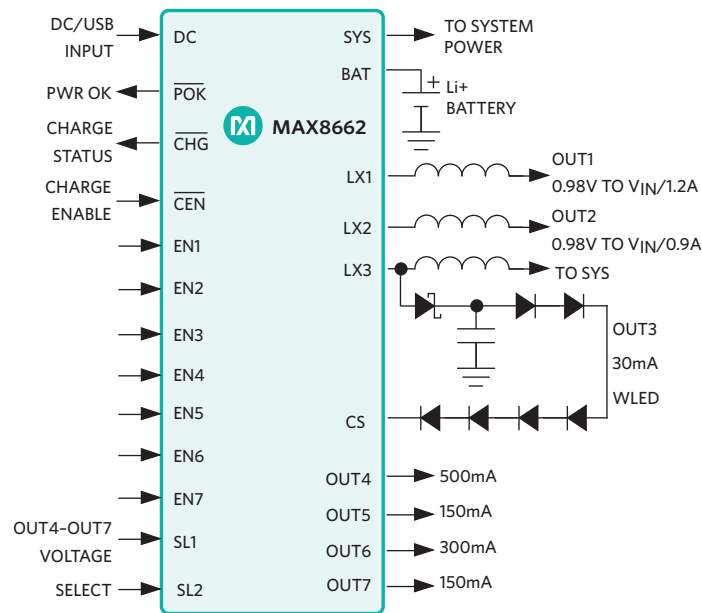
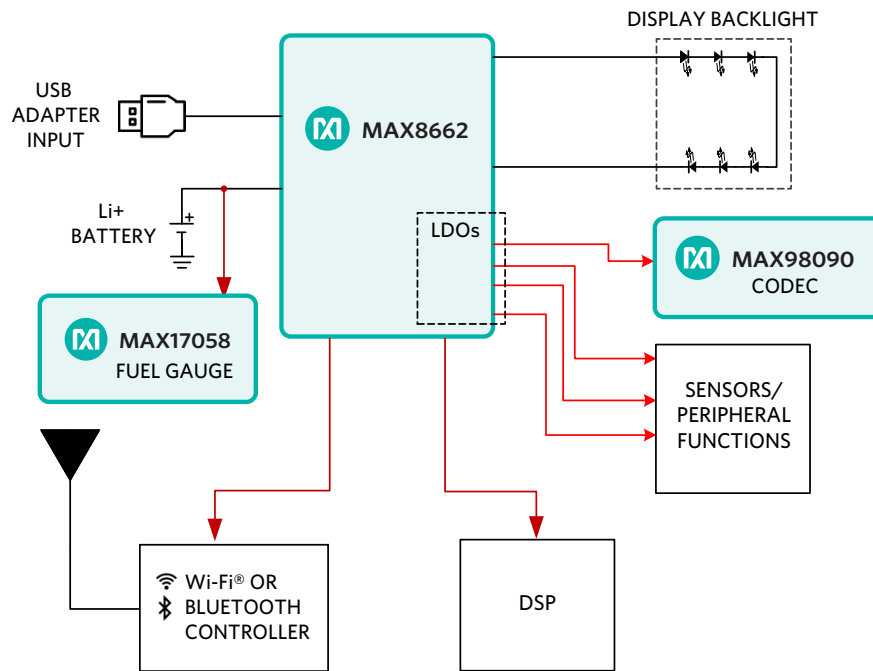

Figure 5. MAX8662 Typical Operating Circuit

Single-Cell Power Management for Portable Music Players

Portable music players often include displays to provide visual feedback to the user. Many displays require lighting to enhance display brightness using an LED backlight. The MAX8662 PMIC has an integrated LED driver to provide backlighting for small displays in portable applications. Additional rails include 2 buck converters for MCU or a Bluetooth controller power supply and 4 LDOs for additional sensors or peripheral functions. An integrated battery

charger with Smart Power Selector technology seamlessly distributes power between the charger input, battery, and load. This reduces processor overhead and provides a stand-alone battery power solution for small handheld devices such as portable music players. The robust features of the MAX8662 are offered in a small 48-pin TQFN (37.2mm² package), which enables small form-factors for portable and handheld applications. An example application circuit for a portable music player is shown in *Figure 6* demonstrating the MAX8662 PMIC's robustness.



*Contact us for information on multi-cell audio solutions.

Figure 6. Portable Music Player Application Using MAX8662 PMIC

Smart Power Selector Convenient Charging

Smart Power Selector technology employs an internal charge-pump supply and internal FETs to seamlessly distribute power between the external input, battery, and system load. Configuration is internally optimized and does not require external components. Smart Power Selector technology is ideal for frequently charged/discharged battery-operated systems, such as handheld devices.

Basic Functions of Smart Power Selector Technology

1. With both the external power supply and battery connected.
 - a) When the system load requirements exceed the capacity of the external power input (Figure 7), the battery supplies supplemental current to the load.

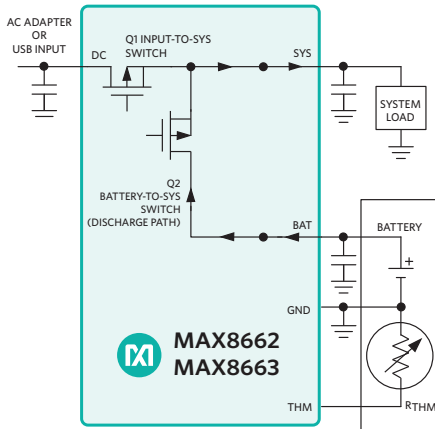

Figure 7. Power Path When $I_{LOAD} > I_{DC}$

2. When the battery is connected and there is no external power input, the system is powered from the battery (Figure 9).

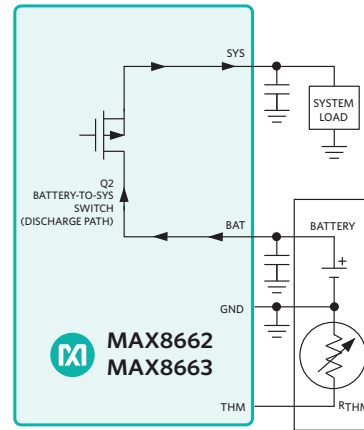

Figure 9. Power Path With Battery, But No External Supply

- 3) When an external power input is connected and there is no battery, the system is powered from the external power input (Figure 10).

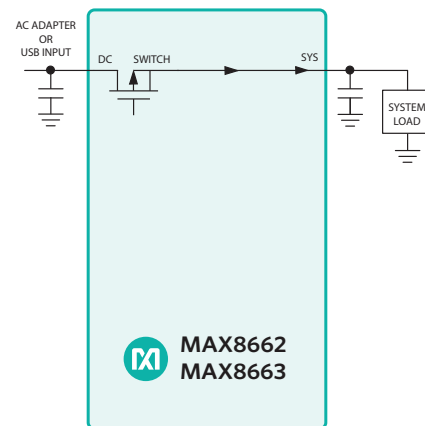

Figure 10. Power Path With External Supply, But No Battery

- b) When the system load requirements are less than the capacity of the external power input (Figure 8), the battery is charged with residual power from the input.

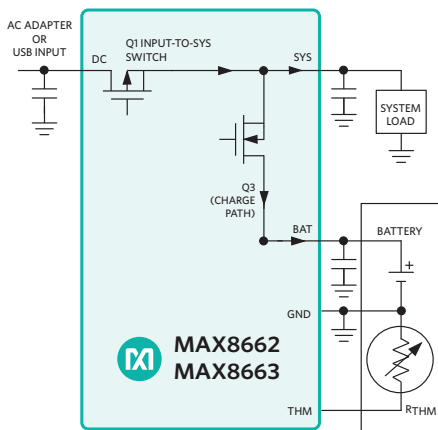

Figure 8. Power Path When $I_{LOAD} < I_{DC}$

Table 1. Power Management IC Product Selector

Part Number	Primary Topology	LCD/LED/Flash/CCD Features	V _{IN} Range (V)	V _{OUT} Range (V)	Max. I _{OUT} (A)	Operating Frequency (kHz)	I _{CC} (max) (mA)	Package/Pins	Smallest Available Package (max with pins) (mm ²)
MAX8660*	Step-down		2.6 to 6	0.725 to 3.3	1.6	2000	0.02	TQFN/40	26
MAX8662*	Step-down	White LED	2.6 to 8	1 to 3.3	1.2	1000	0.1	TQFN/48	37.2
MAX8819*	Step-down	White LED	4.1 to 5.5	1 to 5.3	0.5	1000, 2000	1.33	TQFN/28	16.8
MAX77650* MAX77651*	Step-down	LED indicators	4.1 to 7.25	0.8 to 5.25	0.4		0.06	WLP/30	5.9

Note: All parts listed in this table operate from -40°C to +85°C.

*Evaluation kit available.

Battery Chargers and Fuel Gauges

Mobile devices require high-capacity rechargeable batteries to provide system power. These systems typically use Li+ batteries due to their light weight and large energy density. Our battery chargers offer a variety of features, which enable accurate and robust designs to ensure safe battery-charging solutions. Our fuel gauges monitor remaining battery charge using a proprietary ModelGauge™ algorithm to provide high accuracy. In addition, they offer SHA-256 authentication to prevent battery pack cloning. Together, our battery chargers and fuel gauges (Figure 11) provide the efficiency, accuracy, and protection required to support Li+ battery applications.



Figure 11. Li+ Battery Charging and Fuel Gauging

Li+ Battery Charge Termination

Proper charge termination is imperative to all rechargeable battery-operated devices for extended battery life. Moreover, Li+ batteries require specialized care to avoid disastrous effects due to improper charging. Our Li+ chargers incorporate three charging stages to accommodate safe charging. These charging stages include prequalification, fast-charge, and top-off (Figure 12). However, additional stages may be included to increase battery protection and performance.

In the case of severely depleted Li+ batteries, a large current may potentially cause damage to the battery. **Prequalification** measures and determines an acceptable battery voltage to allow safe charging. The battery is charged using a low current until the voltage rises above a specified limit. Once the battery is at a safe voltage level, fast-charging begins.

Fast-charging requires high current to quickly charge the battery. Charge current is determined by the battery capacity and required charge time; however, battery manufacturers will specify a maximum charge current. The maximum charge current limits the time in which the battery may be safely charged. The fast-charging phase ends with a primary

termination method. Our battery chargers offer a broad range of fast-charge termination methods to suit your design needs.

In the **top-off** stage, the remaining battery capacity is charged with constant voltage. The top-off charging current is terminated based on a timer, which begins count at the beginning of the top-off stage. This stage maximizes capacity to deliver the most from your battery.

Charge Control Methods

Fast-charging is complete once the requirement of primary termination is met. Primary termination comes in a variety of approaches that are battery chemistry dependent. Below is a list of fast-charge termination methods compatible with Li+ batteries.

Current Limit — Sets a maximum charging current limit. Charger remains in constant current (CC) mode at the specified limit until either a maximum voltage is detected, and/or a timer expires. Both maximum voltage and timer are adjustable limits, and thus provide design flexibility.

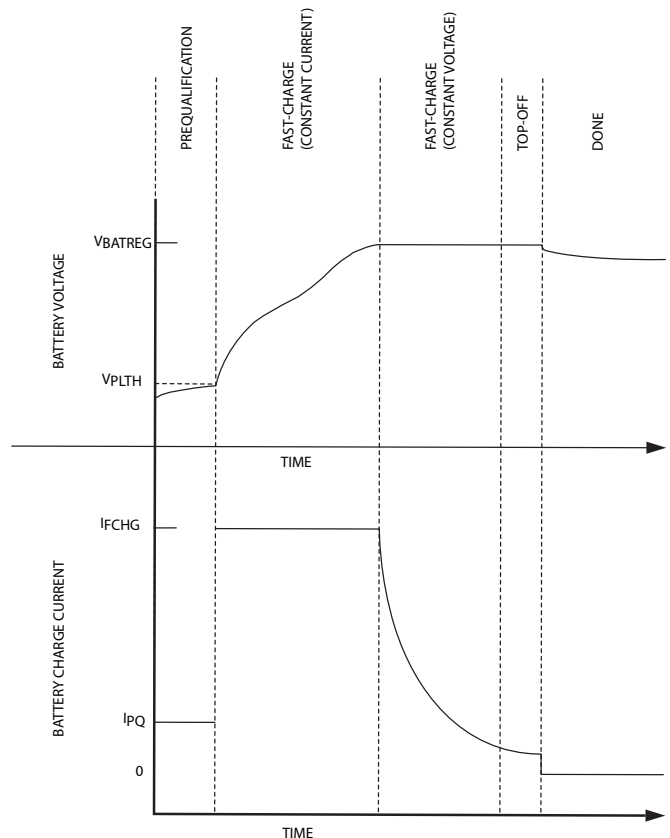

Figure 12. Charging Stages for Safe Charging

Limits are adjustable either through hardware or I²C/SMBus. This method offers fast charging and flexibility in an integrated package.

Minimum Charge Current — The charger initially provides a fixed constant current. Charge current is reduced as the battery approaches maximum voltage. Charging ends once a specified minimum charge current is reached.

External Control — These devices typically have an input to control charge current. This allows designers to implement proprietary charging algorithms using an external microcontroller. These devices offer simplicity and flexibility in a wide variety of applications with a simple microcontroller.

Smart Battery Control — A smart battery has integrated battery management, which communicates charging specifications with a smart charger using SMBus. Charging follows guidelines set by the Smart Battery Charger Specification Revision 1.1.

Timer — Charging terminates based on an expired timer count. Timer begins count when the charging phase is enabled. This method is also used as protection to prevent runaway charging current.

Maximum Temperature — Charging terminates based on battery temperature. A set thermal limit prevents battery overheating, which provides battery protection. This method requires a local battery thermistor to accurately detect battery temperature.

Single-Cell Battery Charger for Handheld Gaming Devices

The fast-growing video game industry continually develops new products with increasingly smaller form-factors while adding more features to enhance user experience. Handheld gaming devices require large batteries to support video processing, real-time motion sensing, wireless communication, and peripheral sensors. This entails a battery charger that must supply a high fast-charge current to quickly charge the battery, while maintaining a small solution size. The **MAX8971** can deliver up to 1.55A of fast-charge current and is available in a 2.18mm x 1.62mm WLP package. A safeout LDO provides power to 5V low-power USB PHY. This battery charger IC is JEITA-compliant, which provides safe charging over a wide temperature range. In addition, the device supports a GSM test mode that provides a 2.3A peak pulse current at 217Hz with a 12.5% on-duty cycle. This test mode allows the manufacturer to test battery performance with transient loads expected from GSM transceivers. This enhances reliability for gaming devices with location and/or data services. *Figure 13* is an example application circuit demonstrating the use of the MAX8971 in a typical handheld gaming system.

Linear vs. Switch-Mode Charging

Battery chargers come in a variety of topologies, each optimized for specific design goals. Mobile applications require low battery voltages; thus, battery chargers are normally step-down devices. Two of the most common battery-charging solutions use either linear or switching topologies to regulate charge current.

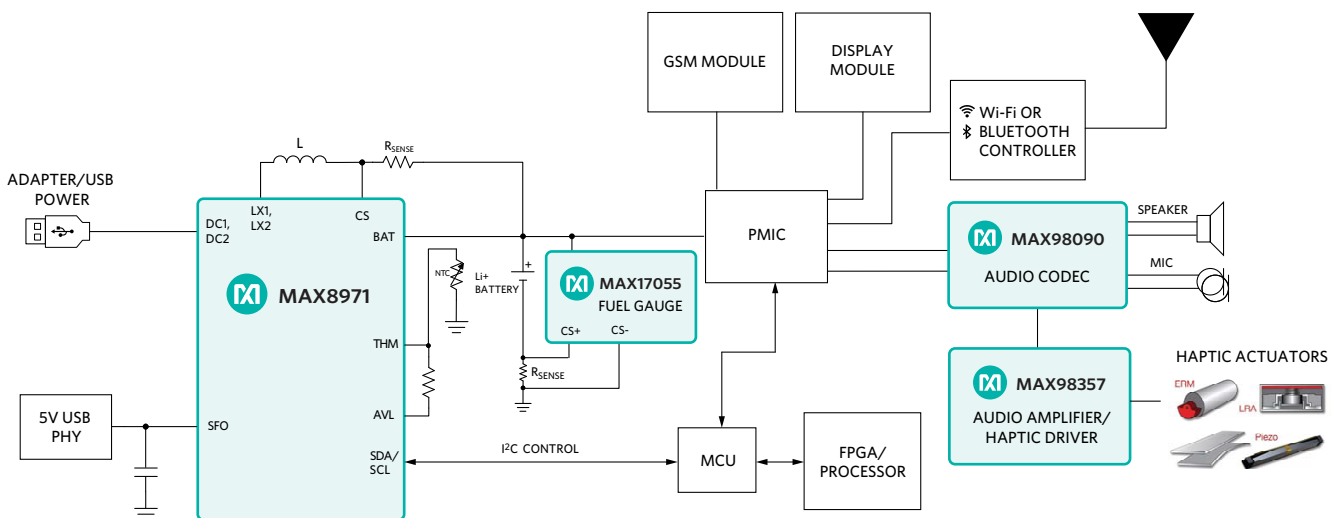

*Contact us for information on multi-cell audio solutions.

Figure 13. Typical Handheld Gaming System Using MAX8971 Battery Charger

Linear chargers adjust the resistance across a high-side FET to regulate charging current to a battery load. Switch-mode chargers employ a buck topology, which regulates charging current by adjusting the duty cycle and/or frequency of a PWM power signal. The PWM power signal is then filtered to achieve the desired charge current.

Benefits of Linear Charging

- Maximum Charging Current < 2A
 - Limited by High-Side FET Thermal Limits
- Low-Cost
 - Reduced Component Count
 - No Magnetic Components
- Small Size
 - Only Input/Output Capacitors
 - No Filtering Required
- Reduced EMI
 - No Switching Noise

Benefits of Switch-Mode Charging

- Maximum Charging Current > 1A
 - Limited by AC and DC Characteristics of Internal Switching FETs
- Wide Input Voltage Range
 - Limited by Duty Cycle
- Greater Complexity
 - Larger Size Mainly Due to LC Filter
 - Variety of Control Systems
- Greater Efficiency
 - Low Power Dissipation
 - Less Thermal Generation
- Greater EMI
 - Switching FETs Induce Noise
 - Inductor EM Field Radiation

Wireless Sensor Battery Charger

Linear battery chargers are a great fit in small systems with low battery capacities such as wireless sensor nodes. These low battery capacity systems require little charge current. The low I_Q of linear battery chargers enable longer battery life. *Figure 14* demonstrates a typical application circuit for a wireless sensor node using the **MAX8814** linear charger set for 500mA of fast charge current.

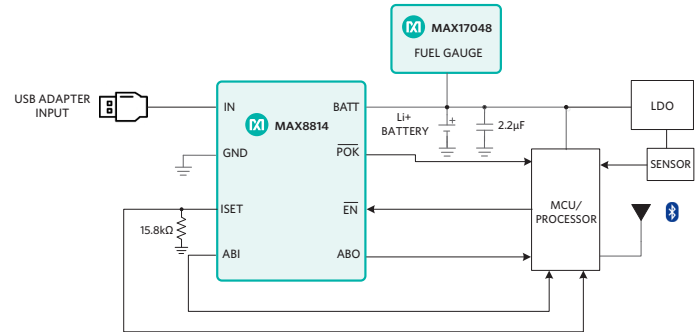
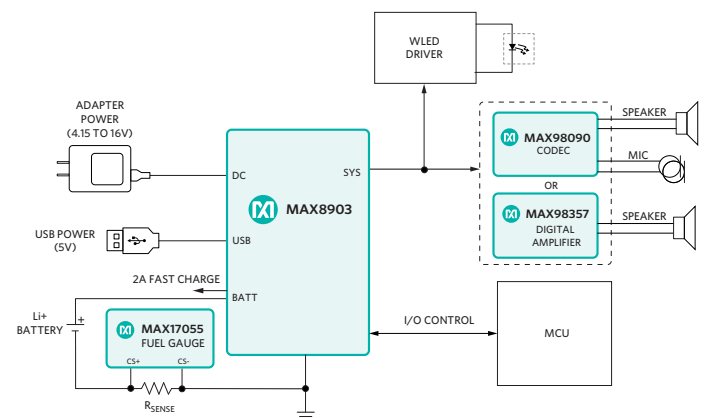

Figure 14. Wireless Sensor Node Using MAX8814 Linear Battery Charger

Single-Cell Digital Camera Battery Charger

For applications with large battery capacities, greater charge current is required. Switch-mode chargers are ideal for these applications due to high efficiency at higher charge currents. Handheld cameras need large batteries to support video processing and encoding. This will require a larger charging current to quickly charge the battery. The **MAX8903_** high-efficiency charger provides up to 2A fast-charge current. A 4MHz switching frequency reduces inductor sizing and overall system size. The dual input allows the user to charge the camera from either an AC adapter or USB input. *Figure 15* demonstrates battery charging in a digital camera application.



*Contact us for information on multi-cell audio solutions.

Figure 15. Digital Camera Application Using the MAX8903_ Switch-Mode Charger

Integrated Battery Charger and Fuel Gauge

Ever-shrinking mobile systems require small solutions with a high level of integration. The **MAX77818** (Figure 16) integrates both a battery charger and fuel gauge to deliver the most from battery-operated applications with system configurability through an I²C serial interface. The battery charger integrates low-loss switches at a 4MHz switching frequency to reduce size. A ModelGauge m5 fuel gauge also provides high accuracy and additional configurability to extend battery life. The charger is re-purposed to support USB On-The-Go (OTG) up to 5.1V at 1.5A using reverse boost capabilities. Altogether, the MAX77818 is a great fit for battery-operated mobile systems where small size and system integration is required.

Key Features of MAX77818

- Dynamic Charging Capabilities
 - 3A Switch-Mode Charger
 - Adapter/USB Input
 - Wireless Charging Input
 - Smart Power Selector
- ModelGauge m5 Battery Fuel Gauge
 - ±1% State-of-Charge Accuracy
 - No Calibration Cycles
 - Low I_Q
 - Time-to-Empty and Time-to-Full Prediction
- Integrated Protection
 - Under/Overvoltage Lockout
 - Adjustable OCP
 - Charge Safety Timer
 - Die Temp Monitor with Thermal Foldback

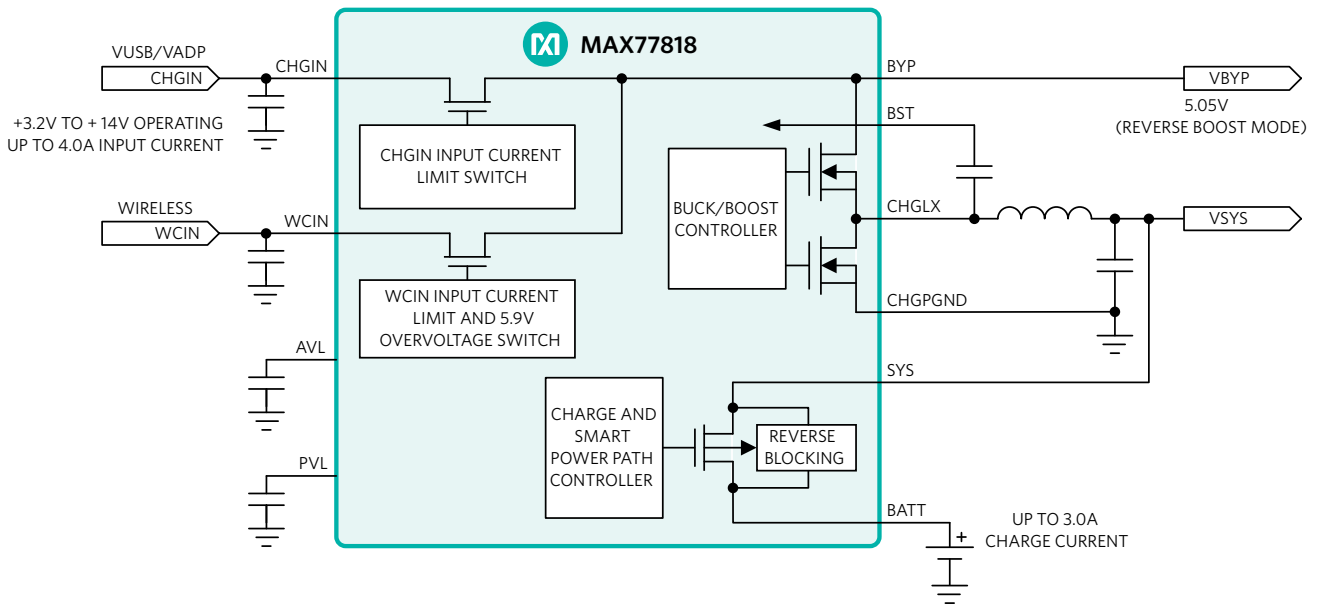
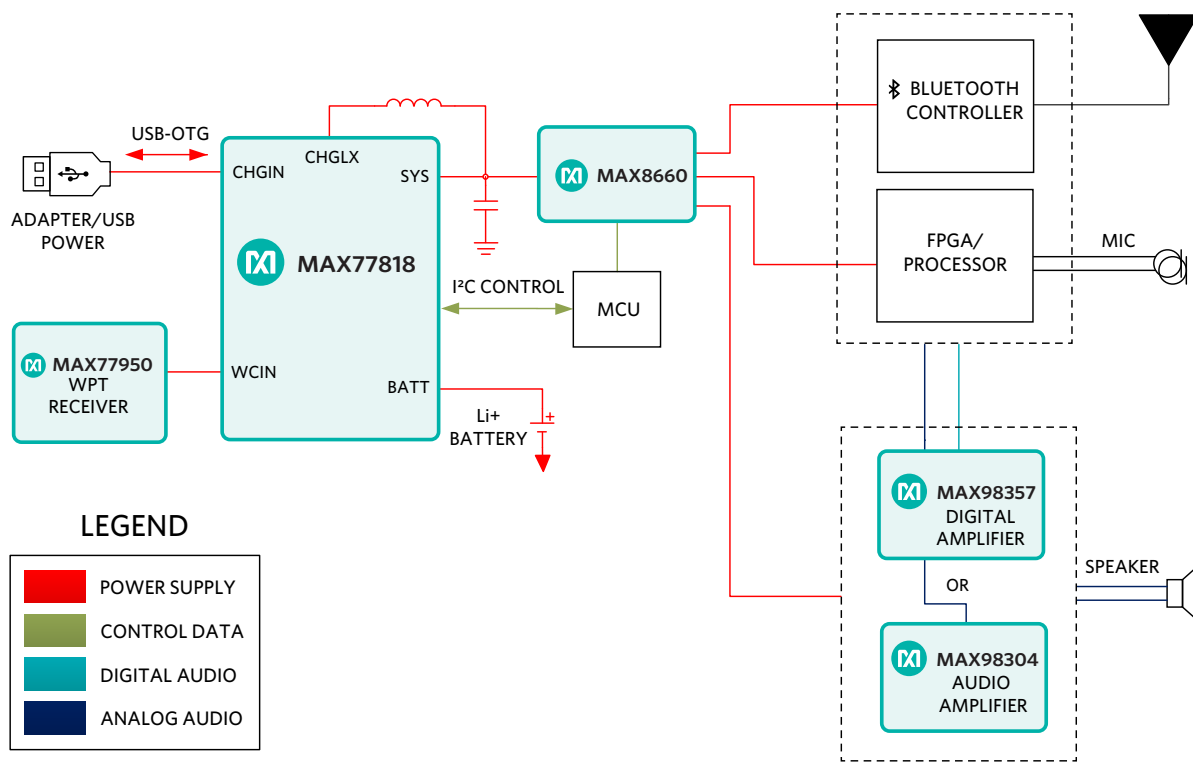

Figure 16. MAX77818 Typical Operating Circuit

Single-Cell Wireless Speaker Charger and Fuel Gauge

Wireless speakers allow us to hear music without being bound to a wall outlet. This modern invention has grown in complexity to include features such as artificial intelligence. These features require larger batteries with greater capacity to support the power demanded by power-hungry processors. It becomes necessary to provide larger charging current to charge the battery within a reasonable time. However, it is also important to keep a small solution size to minimize overall system size. The MAX77818 (Figure 17) is a switch-mode

charger that delivers 3A of fast-charge current in a small 3.87mm x 3.61mm WLP package. Dual-charging inputs allow the user to charge the device from either an adapter or from a wireless charging input. The adapter input offers reverse boost capabilities and may be used to power USB-OTG devices. To add another level of integration, an internal ModelGauge m5 fuel gauge keeps track of the state-of-charge (SOC) to 1% accuracy and offers both time-to-empty and time-to-full predictions. These features enhance wireless speaker performance by providing feedback and additional features to the user.



*Contact us for information on multi-cell audio solutions.

Figure 17. Wireless Speaker Application Using MAX77818 Battery Charger and Fuel Gauge

Table 2. Battery Charger Product Selector

Part Number	Cell Chemistry	Li+ Cells	Protected V_{IN} (max) (V)	Charger (V)	Charge Rate Set By	Max. I_{CHG} (A)	Charge Termination	Charge Regulation	Package/Pins	Smallest Available Package (max with pins) (mm ²)
MAX1501*	Li+, Li-Poly, NiCd, NiMH	1	13	4.1, 4.2, 4.5, 4.95	Resistor	1.4		Linear	TQFN/16	26
MAX1555	Li+, Li-Poly	1	13	4.2	Preset	0.28		Linear	TSOT/5	8.3
MAX1874*	Li+	1	18	4.2	Logic input, resistor	1	External control	Linear	TQFN/16	26
MAX8606*	Li+, Li-Poly	1	14	4.2	Logic input, resistor	1	Minimum charge current	Linear	TDFN-EP/14	9.6
MAX8677_*	Li+, Li-Poly	1	16	4.2	Logic input, resistor	1.5	Minimum charge current	Linear	TQFN/24	16.8
MAX8808_*	Li+, Li-Poly	1	15	4.2	Resistor	1		Linear	TDFN-EP/8	4.2
MAX8814*	Li+, Li-Poly	1	28	4.2	Analog input, resistor	0.6		Linear	TDFN-EP/8	4.2
MAX8856	Li+	1	14	4.2	Logic input, preset, resistor	1	Minimum charge current	Linear	TDFN-EP/14	9.6
MAX8895X*	Li+	1	14	4.2	External source, Resistor	1.85	Minimum charge current	Linear	WLP/25	7.9
MAX8903A	Li+, Li-Poly	1	20	4.2	Preset, resistor	2	Minimum charge current	Switch mode	TQFN/28	16.8
MAX8934A	Li+, Li-Poly	1	14	4.2	Logic input, resistor	1.5	Minimum charge current, timer	Linear	TQFN/28	16.8
MAX8971*	Li+, Li-Poly	1	22	4.1, 4.15, 4.2, 4.35	I ² C/SMBus	1.55	Minimum charge current, timer	Switch mode	WLP/20	3.53
MAX77301*	Li+, Li-Poly	1	16	4.1, 4.15, 4.2, 4.05	I ² C/SMBus	0.9	Current limit, timer	Linear	WLP/25	6.0
MAX77818*	Li+, Li-Poly	1	16	3.625 to 4.7 (25mV Steps)	I ² C/SMBus	3	Minimum charge current, timer	Switch mode	WLP/72	13.95

Note: All parts listed in this table operate from -40°C to +85°C.

*Evaluation kit available.

Fuel Gauges and the ModelGauge m5 Algorithm

Mobile systems require high-accuracy fuel gauging to estimate remaining capacity and maximize battery life. The ModelGauge m5 fuel gauge algorithm accurately estimates SOC using open-circuit voltage (OCV) and coulomb counting. In addition, adaptive mechanisms learn battery capacity as it ages. This ensures a longer battery run-time and is offered in a small solution size. Additional features beyond SOC include time-to-full, and time since first power-up. ModelGauge m5 also logs thirteen critical parameters over battery lifetime. These parameters are used for fault analysis to provide robust safety and security. The following list of ModelGauge m5 features constitute a highly accurate SOC

OCV - The original ModelGauge algorithm estimates the battery OCV, even during current flow. Battery OCV is correlated to battery characterization data to determine SOC. A battery characterization process is required

to implement the OCV method. Battery current is not measured using this method; thus, a current-sense resistor is not required, which reduces bill of materials cost and size.

Coulomb Counting - Coulomb counting measures battery current to determine the amount of charge the battery has gained or lost. Coulomb counting by itself offers better short-term accuracy than OCV, but over the longer term, it injects offset drift that severely degrades accuracy.

Cycle+ - Age forecasting algorithm to predict end-of-life, due to battery degradation with age and use.

Converge-to-Empty - Eliminates SOC error that occurs near empty.

Featured Technology: EZ Config

Previous algorithms require data from a factory-based battery characterization. For most batteries, EZ Config provides high-accuracy fuel gauging without in-depth battery characterization, which allows fast time-to-market designs. EZ Config logs the user-specified battery type and characteristics needed by the m5 algorithm.

EZ Config Parameters

1. Cell Size (mAH)
2. Empty Voltage
3. Pack Configuration

A graphical user interface (GUI) is available for all m5 devices, as pictured on the right. The GUI comes equipped with a battery configuration wizard, battery performance metrics, and real-time performance graphs. This enables designers to quickly evaluate battery and system performance. EZ Config is only offered on select ModelGauge m5 devices; however, characterization services are still available for the entire ModelGauge family of devices.

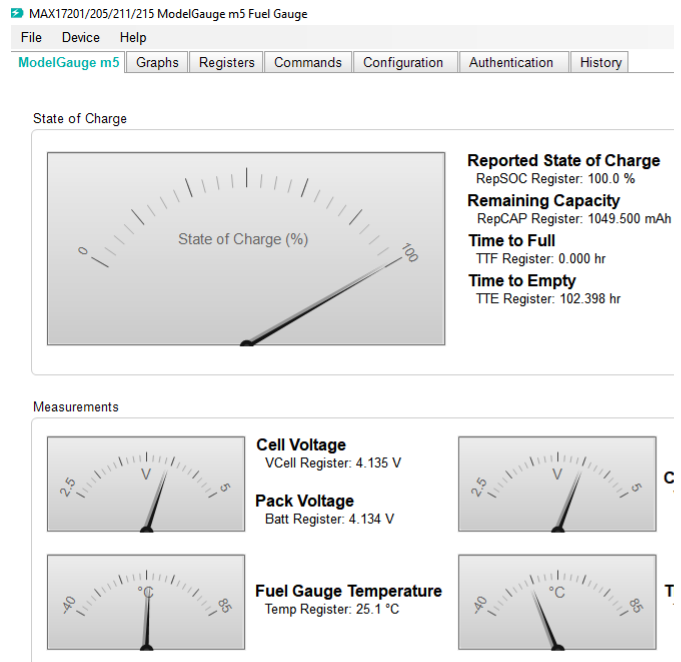

ModelGauge m5's EZ Config Tool Interface

MAX17055 High-Accuracy Fuel Gauge

The combined features of ModelGauge m5 result in a highly accurate SOC estimation throughout the battery's lifetime. Effects such as cell aging, temperature, and discharge rate are automatically and internally compensated. Moreover, ModelGauge m5 EZ devices, such as the **MAX17055**, allow rapid prototyping by eliminating the need for a battery characterization process (*Figure 18*). This reduces development costs without sacrificing fuel gauge accuracy. Over 300 different batteries were tested using the EZ configuration. Performance results show that 97% of batteries have less than 3% error during discharge. The high-accuracy and rapid development capabilities of the MAX17055 fuel gauge allow for implementation in a wide variety of single-cell Li+ applications (*Figure 19*). The following are key features that govern the outstanding capabilities of the MAX17055.

Key Features of MAX17055

- ModelGauge m5 EZ
 - No Battery Characterization Required
 - Robust Against Battery Variation
 - Eliminates Near-Empty Voltage Error
 - Eliminates Coulomb Counter Drift
 - Current, Temperature, and Age-Compensated
 - Does Not Require Empty, Full, or Idle States
- Low 7µA Operating Current
- Wide Sense Resistor Range
 - 1mΩ to 1000mΩ
 - PCB Metal Sensing + Temperature Compensation
- Supports Li+ and Variants Including LiFePO4
- ±1°C Internal Temperature or Thermistor
- Dynamic Power Estimates Power Capability During Discharge
- Predicts Remaining Capacity Under Theoretical Load
- Alert Indicator for Voltage, SOC, Temperature, Current, and 1% SOC Change

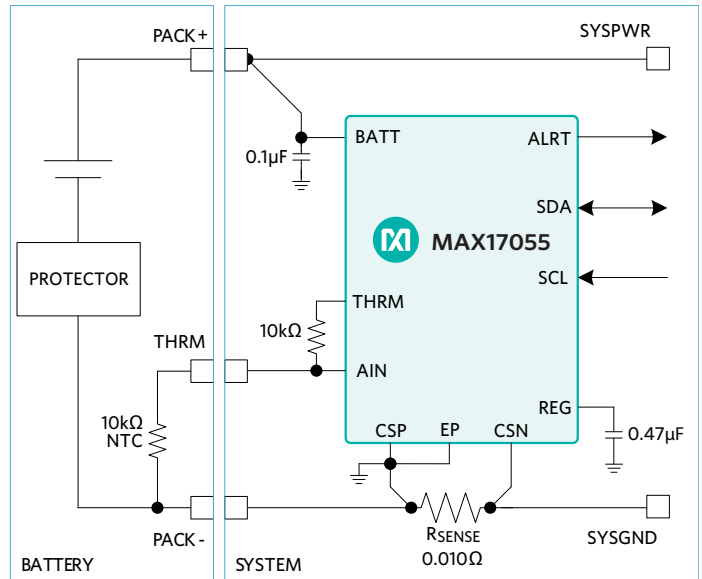

Figure 18. MAX17055 Fuel Gauge in a Battery Pack System

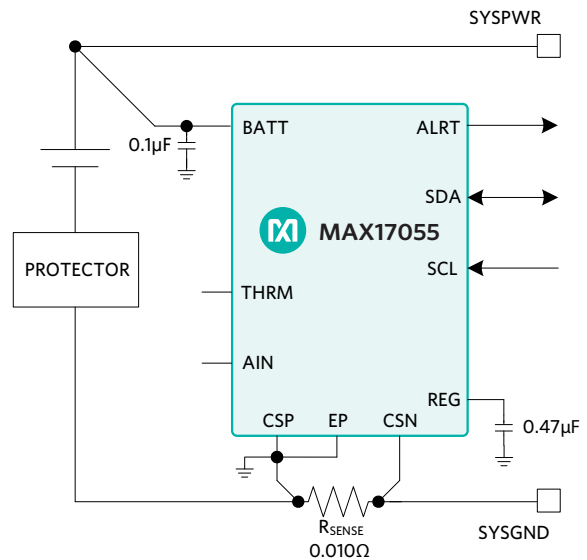

Figure 19. MAX17055 Fuel Gauge in a Captive Battery System

Counterfeit Battery Prevention with SHA-256 Fuel Gauge Authentication

Systems with replacement batteries, sensors, peripherals, modules, or other consumables are commonly targeted by unauthorized after-market companies. These unauthorized companies produce counterfeit modules that introduce safety concerns, reduce the quality of the application, and generally negatively impact the OEM solution. Introducing secure authentication into the solution enables the host system to test sensor or module authenticity, and acts if a counterfeit device is detected (*Figure 20*). Batteries are a common counterfeit target, since they are found in all mobile devices. Fuel gauge authenticators combine the SOC accuracy of ModelGauge m5 with the security of SHA-256 encryption (*Figure 21*). The result is a highly accurate fuel gauge with increased reliability. *Figure 22* is a demonstration of battery authentication using the **MAX17201** SHA-256 fuel gauge for a single-cell battery pack.

In the configuration shown by *Figure 22*, the system host sends an authentication command via the host microcontroller unit (MCU). Once authentication is complete, the MCU enables the system PMIC for power distribution. If the MAX17201 returns an invalid authentication result to the MCU, the MCU does not enable the PMIC and power is not distributed to the system. SHA-256 authentication is performed internally in both the fuel gauge and the MCU.

Alternatively, a simpler scheme using a precomputed challenge-response pair stored in the MCU memory may also be implemented.

The MAX172xx family of SHA-256 fuel gauges (Table 3) offer secure authentication to prevent unauthorized battery-pack cloning. SHA-256 allows the system host to verify a replacement battery. SHA-256 authentication between system host and battery pack slave is accomplished via challenge and response. In challenge-and-response authentication, the host sends a challenge by providing a unique code.

Table 3. Fuel Gauges with SHA-256 Authentication

Fuel Gauge	Battery Type	Interface
MAX17201	1-Cell Li+	2-Wire
MAX17205	Multi-Cell Li+	2-Wire
MAX17211	1-Cell Li+	1-Wire®
MAX17215	Multi-Cell Li+	1-Wire

Note: Given the secure and application-sensitive nature of secure authentication products, device details are omitted from this document. The full version of individual device data sheets, available under a nondisclosure agreement (NDA), provides this information.

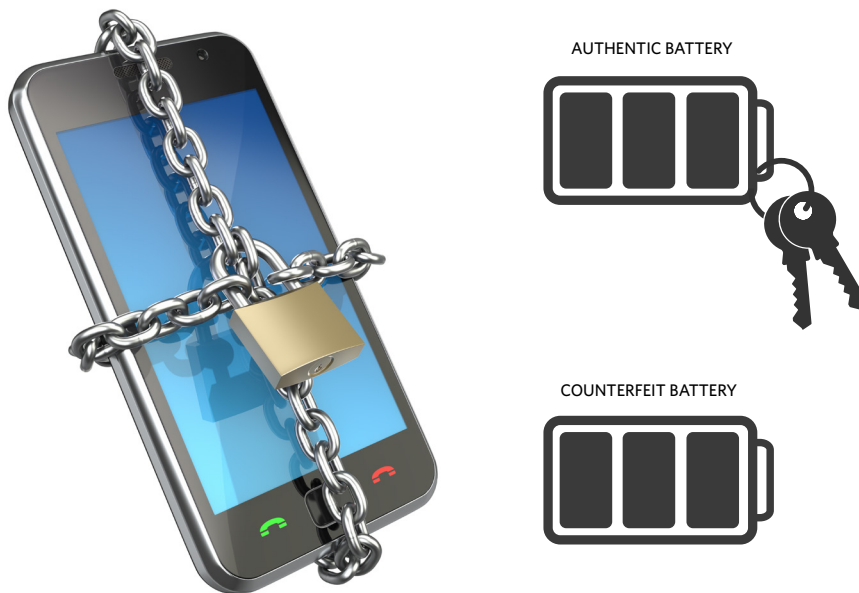

Figure 20. Counterfeit Battery Prevention Using Authentication

The slave device then responds with a 256-bit message authentication code (MAC). The MAC is generated using a SHA engine, which contains the secure hash algorithm (SHA). The SHA engine uses the host's challenge along with a slave secret, user memory, and additional data to generate the MAC response. The response of the slave device is a unique MAC, which is then sent back to the host for verification. Once the host verifies the response MAC, the battery pack is considered authentic.

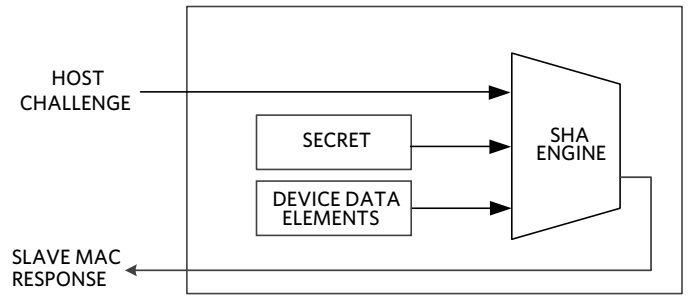

Figure 21. Authentication Procedure Block Diagram

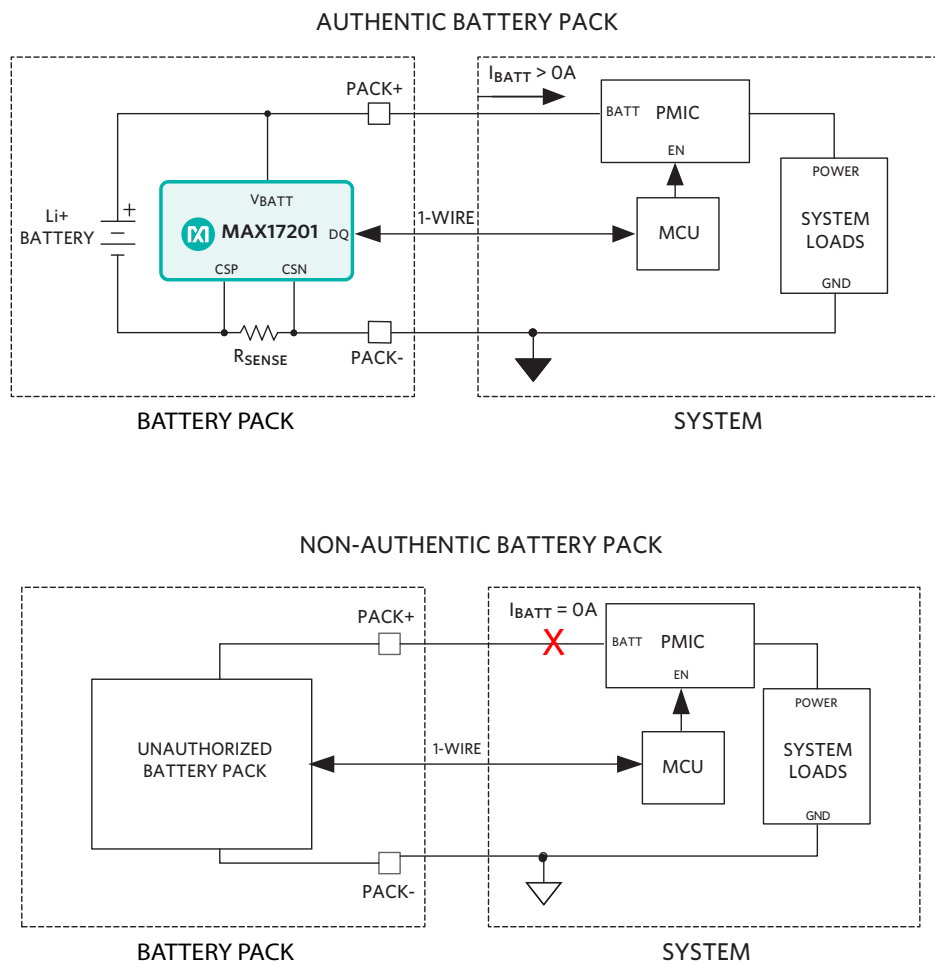

Figure 22. Battery Pack Authentication Using the MAX17201 Fuel Gauge

Low-Power Fuel Gauge for Wireless Sensors

Wireless sensor networks consist of many autonomous devices working together to sense the environment around them. These sensors may have different functionalities, but they all require three main components which include a battery, a sensor, and a radio. An important aspect of the wireless sensor is its lifetime, which is directly related to the battery life. Our fuel gauges provide a measure of the remaining battery capacity with minimal power consumption to enable longer battery life. As an example, the **MAX17048** uses the ModelGauge algorithm to predict an accurate SOC. More importantly, the MAX17048 typically consumes only $3\mu\text{A}$ of quiescent current in hibernate mode (**Figure 23**), while still providing accurate fuel gauging. This allows wireless sensors to estimate battery capacity without excessively draining the battery. Hibernate mode works best in applications where the battery load is less than the $C/4$ -rate, which is ideal for wireless sensors that consume little current. Often, the battery load can significantly increase during a communication event in the radio module. During such heavy loads, the devices can be forced into active mode (**Figure 24**) to ensure accurate gauging. The low quiescent current and versatile configurability of the MAX17048 is well-suited for fuel gauging in wireless sensor nodes.

Key Features of MAX17048

- ModelGauge Algorithm
 - Provides Accurate State-of-Charge
 - Compensates for Temperature and Load Variation
 - Does Not Accumulate Errors, Unlike Coulomb Counters
 - Eliminates Current-Sense Resistor
- Ultra-Low Quiescent Current
 - $3\mu\text{A}$ Hibernate
 - $23\mu\text{A}$ Active
- Battery-Insertion Debounce
- Programmable Reset for Battery Swap
- Configurable Alerts
 - Low SOC
 - 1% Change in SOC
 - Battery OV/UV
 - V_{RESET} Alert
- I²C Interface

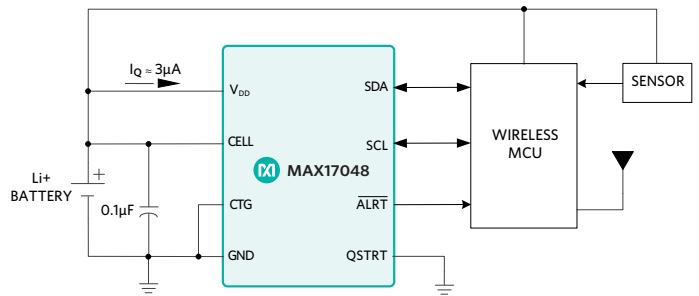

Figure 23. MAX17048 Fuel Gauge in Hibernate Mode

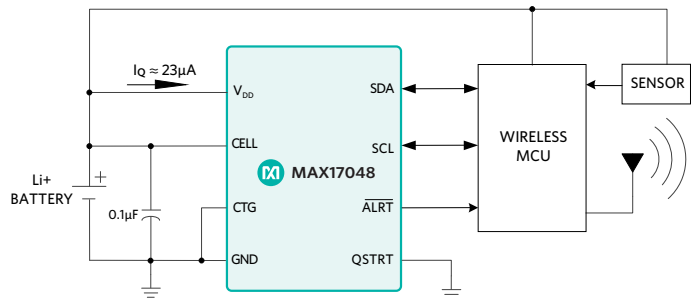

Figure 24. MAX17048 Fuel Gauge in Active Mode

Multi-Cell Fuel Gauge for Robots and Drones

Robots and drones require multiple Li+ battery cells to obtain higher operating voltages. The higher operating voltage is required to drive the motors in these systems. Due to varying capacities between stacked cells, the operating voltage of each individual cell will diminish at different rates during operation. Cell balancing is used to maintain equivalent voltages across all cells, which extends the life of the battery pack. The **MAX17215** can cell balance up to three cells and is a stand-alone fuel gauge, which is also beneficial to this application.

Monitoring the SOC of the battery pack allows the user to maximize battery run-time and lifetime. The MAX17215 uses the ModelGauge m5 EZ Config to determine a highly accurate SOC without any battery characterization procedure. In addition, the MAX17215 provides SHA-256 authentication to ensure the battery pack is genuine, thus increasing system reliability. *Figure 25* shows an example application demonstrating the MAX17215 in a drone application.

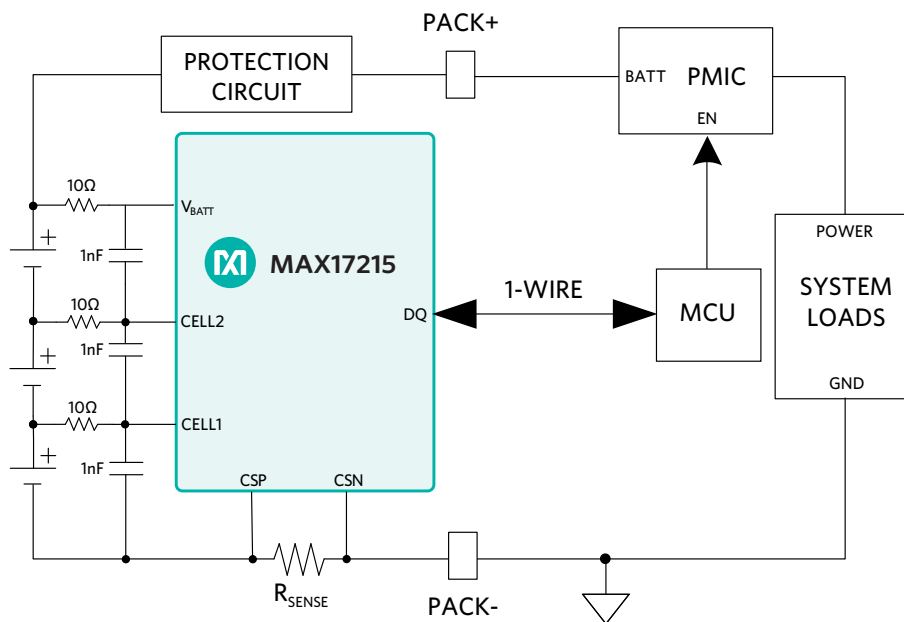

Figure 25. MAX17215 Multi-Cell Fuel Gauge for Robot/Drone Applications

Table 4. ModelGauge Fuel Gauge Product Selector

Part Number	Functions	Battery Type	Interface	User Data Storage (Bytes)	Parameters Measured	Fuel Gauge Algorithm	V _{SUPPLY} (min) (V)	V _{SUPPLY} (max) (V)	Package/Pins	Smallest Available Package (max with pins) (mm ²)
ModelGauge										
MAX17040*	Fuel gauge	1-cell Li+	2-wire		State-of-charge, voltage	ModelGauge	2.5	4.5	TDFN-EP/8	6.3
MAX17048*	Fuel gauge	1-cell Li+	2-wire		C Rate, state-of-charge, voltage	ModelGauge	2.5	4.5	TDFN/8, WLP/8	4.4
MAX17058*	Fuel gauge	1-cell Li+	2-wire		State-of-charge, voltage	ModelGauge	2.5	4.5	WLP/8	4.4
ModelGauge m3										
MAX17050*	Fuel gauge	1-cell Li+	2-wire		Current, state-of-charge, temperature, time, voltage	ModelGauge m5	2.3	4.5	WLP/9	2.1
ModelGauge m5										
MAX17055*	Fuel gauge, status monitor	1-cell Li+	2-wire		Current, state-of-charge, temperature, time, voltage	ModelGauge m5	2.5	4.9	WLP/9	2.1
MAX17201*	SHA-256 authentication, fuel gauge, status monitor	1-cell Li+	2-wire	156 NVM	Current, state-of-charge, temperature, time, voltage	ModelGauge m5	2.3	4.9	TDFN-CU/14, WLP/15	3.84
MAX17205*	SHA-256 authentication, fuel gauge, status monitor	Multi-cell Li+	2-wire	156 NVM	Current, state-of-charge, temperature, time, voltage	ModelGauge m5	4.2	20	TDFN-CU/14, WLP/15	3.84
MAX17211*	SHA-256 authentication, fuel gauge, status monitor	1-cell Li+	1-wire	156 NVM	Current, state-of-charge, temperature, time, voltage	ModelGauge m5	2.3	4.9	TDFN-CU/14, WLP/15	9.6
MAX17215*	SHA-256 authentication, fuel gauge, status monitor	Multi-cell Li+	1-wire	156 NVM	Current, state-of-charge, temperature, time, voltage	ModelGauge m5	4	20	TDFN-CU/14, WLP/15	3.84
MAX77818*	Battery charger, fuel gauge	1-cell Li+	2-wire		Current, state-of-charge, temperature, time, voltage	ModelGauge m5	2.8	4.98	WLP/9	2.1

Note: All parts listed in this table operate from -40°C to +85°C.

*Evaluation kit available.

DC-DC Converters

Mobile devices typically require multiple voltage rails from a single battery, which requires highly efficient power conversion in a small footprint. Our broad range of high-frequency inductor-based switching converters provide the small form-factor demanded by mobile applications, while maintaining high efficiency (*Figure 26*). The required output voltage rails may be either greater or less than the battery voltage. Buck converters are used to step down the input voltage, while boost converters are used to step up the input voltage.

Buck-boost converters provide dual functionality to both step down and step up the input voltage; hence, these converters are useful in mobile applications where the battery voltage may vary above and below the output voltage. These solutions provide the power required by processors, memory, and/or other peripheral functions in mobile systems. In addition, many of these solutions have SPICE models for design and simulation. Our **EE-Sim[®] DC-DC Converter Design Tool** allows for rapid design and customization using these models.

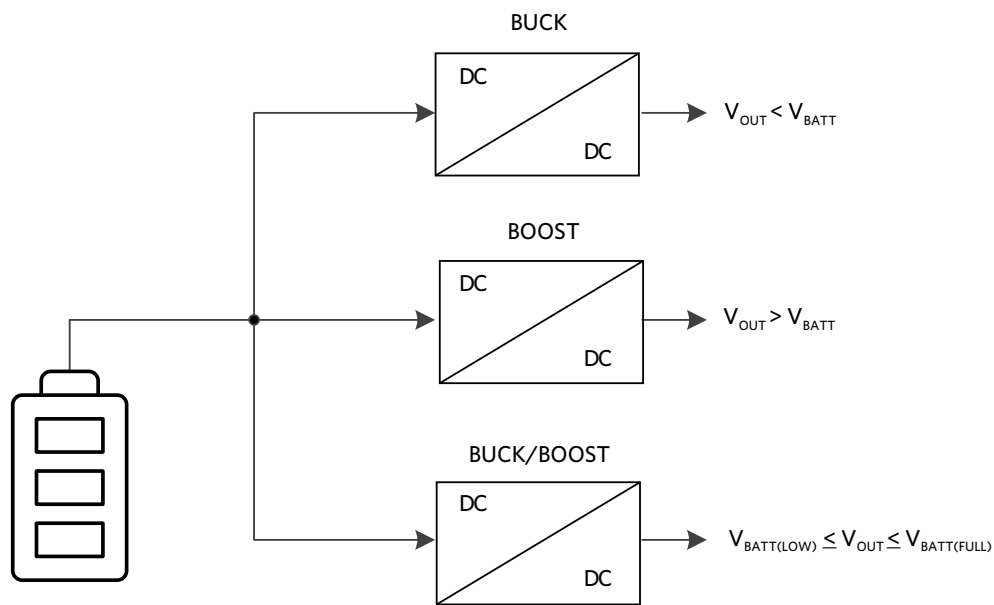

Figure 26. Typical DC-DC Converters for Battery-Powered Applications

Remote Sense Enhances Regulation and Load Transient Response

High-performance mobile devices typically employ processors or FPGAs to accomplish computationally expensive tasks. These systems require an accurate low-voltage supply with high-current capability. Voltage accuracy becomes challenging in these applications, since the high-current path will generate voltage drops due to parasitic resistances. In addition, sudden load changes produce high-frequency currents, which generates noise due to component and PCB parasitic impedances. If not properly designed, a load change may cause instability in the converter.

Feedback compensates for voltage drops due to high-current paths; however, conventional converters do not compensate for the high-current load return path, as shown in *Figure 27*. The return path will exhibit a voltage drop between both the load processor and converter due to the return-path parasitics. In the event of a load step, the feedback amplifier will observe the voltage across the load (V_{LOAD}) as well as the voltage drop created by the load step and return path parasitics (V_{DROP}). Naturally, this will cause inaccuracies in the output voltage and may even cause instability.

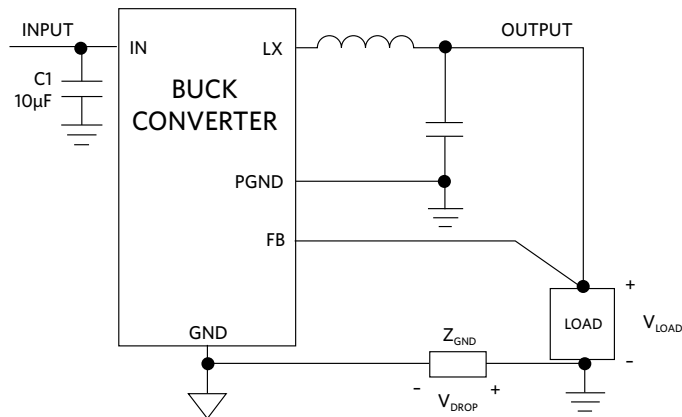

Figure 27. Buck Converter Ground Impedance Affects Feedback Signal

Our high-performance DC-DC converters are tailored to processor and/or FPGA operation by providing remote-sense connections to compensate for return-path parasitics. These converters, such as the **MAX8649/MAX8649A**, integrate a differential amplifier to accurately measure the differential voltage across the load, as shown in *Figure 28*. Remote sensing compensates for return-path parasitics to provide high-accuracy regulation. In addition, high-frequency currents generated by a load step will have minimal effect on the accuracy of the load voltage. It is important to note proper Kelvin sense connections are required for the remote sense pins to accurately measure the feedback voltage. *Figure 29* demonstrates proper Kelvin Sense connections.

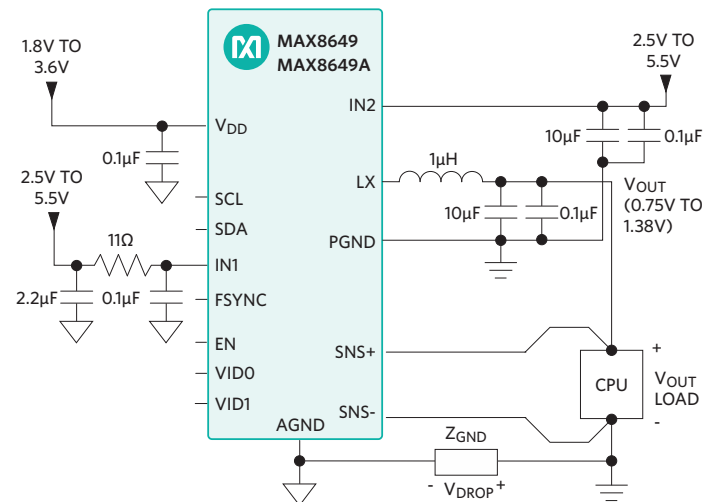

Figure 28. MAX8649/MAX8649A with Differential Feedback to Bypass GND Impedance

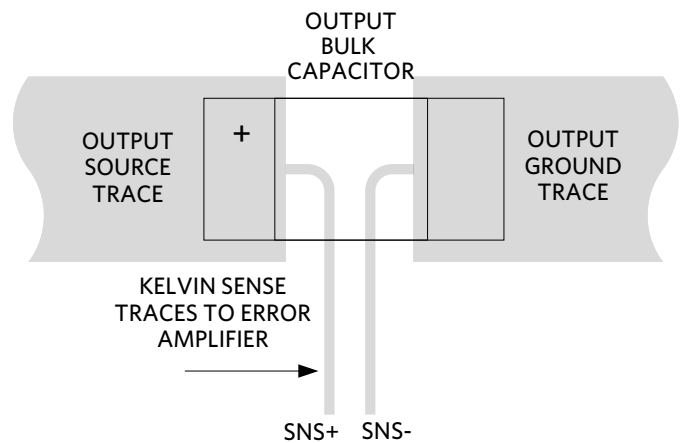

Figure 29. Proper Kelvin Sense Connections

Voltage Positioning Increases Load Transient Immunity

Rapid load transients in processor and FPGA applications cause the output voltage to momentarily shift while the controller compensates for the sudden load change. Voltage undershoot occurs when the load quickly transitions from a low current to a high current. This causes the output capacitors to discharge faster than they can be charged; thus, causing a drop in output voltage. Similarly, voltage overshoot occurs when the load transitions from a high current to a low current. Overshoot and undershoot may be as much as 5% or greater of the nominal output voltage (Figure 30). Voltage positioning compensates for sudden load changes,

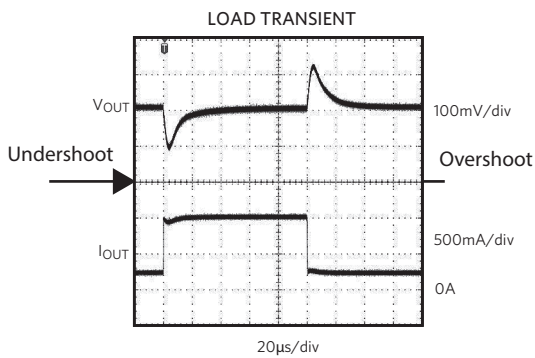

Figure 30. Load Step Without Voltage Positioning

which effectively reduces the output voltage undershoot and overshoot during load transients (Figure 31).

Voltage positioning (Figure 32), for the MAX1556/MAX1556A, places the output voltage slightly above nominal regulation at no load and slightly below nominal regulation at full load. As output load changes, a small but controlled amount of load regulation (“load-line”) error occurs on the output voltage (Figure 33). This voltage positioning architecture allows the output voltage to respond to sudden load transients in a critically damped manner, effectively reducing the amount of output capacitance needed when compared to classical PWM control.

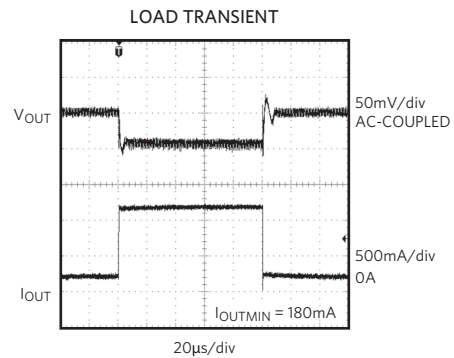

Figure 31. Load Step with Voltage Positioning

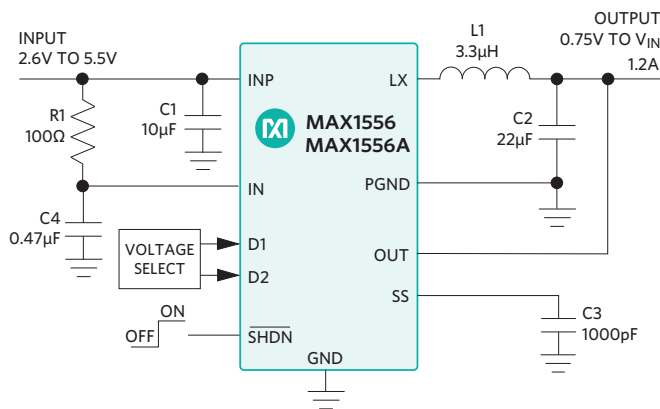

Figure 32. MAX1556/MAX1556A Typical Operating Circuit

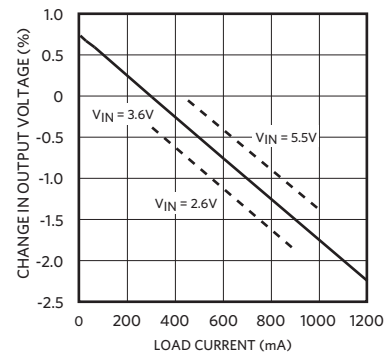

Figure 33. MAX1556 Voltage Positioning Load Line

USB Type-C Port Controller Power Supply

Prevailing USB Type-C technology provides greater power transfer by increasing USB voltage from 5V to either 9V, 15V, or 20V. Mobile devices employ USB port controllers to negotiate battery-charging conditions. Moreover, the port controller power supply requires a wide input voltage range to support USB Power Delivery 3.0 (PD) specifications. The **MAX77596** (Figure 34) regulates output voltage from the default 5V USB voltage or up to 24V to meet all PD 3.0 voltage range specifications. In addition, the port controller is always-on to monitor when a device is plugged in. This requires a low I_Q to reduce power consumption and extend battery life. The MAX77596 provides a $1.1\mu\text{A}$ quiescent current to continuously power the port controller without excessive battery drain. The features of the MAX77596 make it an ideal power supply for USB port controllers.

Key Features of MAX77596

- Wide Input Voltage Range
 - $V_{IN} = 3.5\text{V to }24\text{V}$
- Extends Battery Life
 - $I_Q = 1.1\mu\text{A}$
 - 86% Peak Efficiency ($12V_{IN}, 3.3V_{OUT}$)
- Small Solution Size
 - 1.7MHz Operating Frequency
 - 10-Pin TDFN (2mm x 2.5mm)
- Integrated Protection
 - Short-Circuit, Thermal Protection
 - Soft-Start
 - Tolerates 42V Input Transients

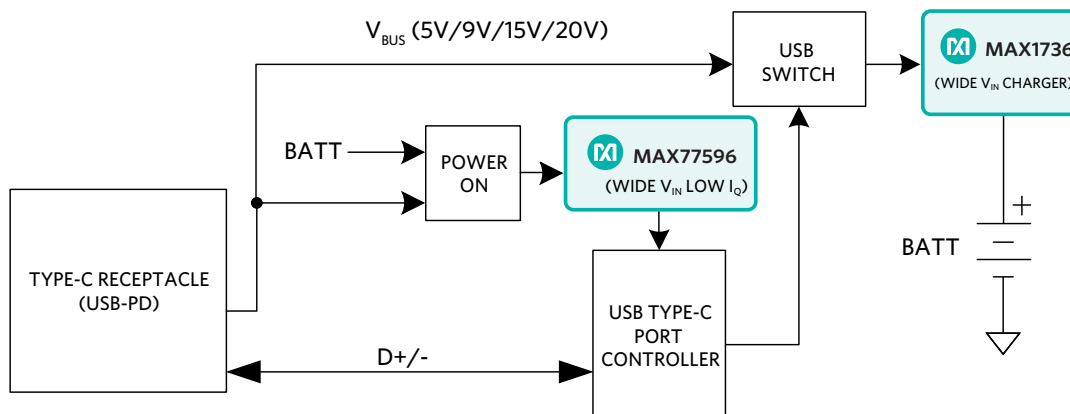

Figure 34. MAX77596 Wide V_{IN} Buck Converter for USB Type-C Port Controller

Improve Boost Efficiency in Battery Applications with Auto-Track

Battery-operated devices often require boost converters to increase battery voltage for peripheral device power. The boost converter must maintain high efficiency throughout battery life, where battery voltage will vary. The **MAX8969** (Figure 35) features Auto-Track Mode (ATM) to maintain high efficiency for a wide range of input voltages. ATM turns on the output FET when the input voltage exceeds 95% of the output voltage. This allows the output voltage to follow the input voltage and eliminates switching losses for higher efficiency. When the input voltage is between 80% and 95% of the output voltage, switching occurs at a reduced frequency, which reduces switching losses and provides greater efficiency. Switching between regulation states provides high efficiencies across battery life, where battery voltage is expected to fluctuate.

Key Features of MAX8969

- Flexible System Integration
 - Up to 1A Output Current
 - 2.5V to 5.5V Input Voltage Range
 - 3.3V to 5.7V Output Voltage Options
- Extend Battery Life
 - Over 90% Efficient
 - True Shutdown™
 - Light-Load Skip Mode
- Small Package and Components
 - 9-Bump 1.25mm x 1.25mm WLP Package
 - 3MHz PWM Switching Frequency
- Integrated Protection
 - Soft-Start
 - Input Undervoltage Lockout
 - Short-Circuit Protection
 - Overtemperature Shutdown

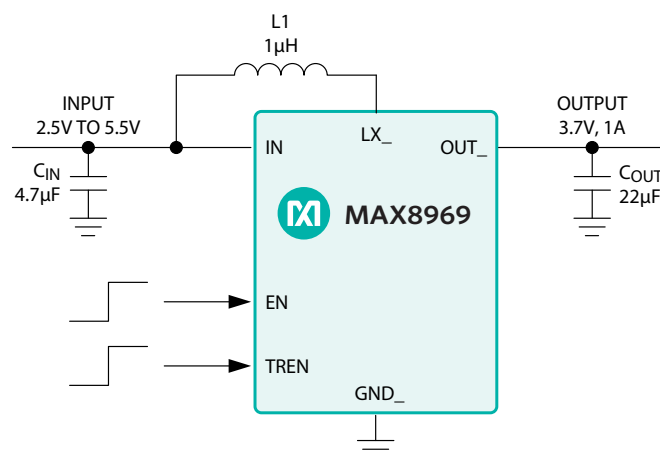

Figure 35. MAX8969 Auto-Track Boost Converter Typical Application Circuit

Increase Battery Life with True Shutdown

Step-up converters exhibit a DC path between input and output through the inductor and output FET body diode. If a load is present, this path will source current from the input even when the converter is off. In synchronous switching, the body diode of the output NFET is forward-biased in shutdown and allows current flow from the battery to the output. If the load cannot be shut down, an external switch is required to avoid depleting the battery during shutdown. A proprietary design uses an output PFET to position the body diode and prevent conduction. This allows the output to fall to GND in shutdown and eliminates the connection between the input and output. True Shutdown is critical for battery-powered devices that require a higher bus voltage than what is provided by the battery. *Figures 36 and 37* demonstrate a typical boost converter and the True Shutdown boost. The output voltage is only required for short durations; thus, shutdown occurs often.

When shutdown mode is enabled, the traditional boost converter exhibits current draw through the body diode, whereas the True Shutdown boost blocks current. This extends battery life by reducing quiescent power draw from the battery when the boost converter is not active.

Benefits of True Shutdown:

- Reduces System Size and Cost
 - No Load Switch Required
- Increases Battery Life
 - No Current Draw From Load (When Converter Off)
- Battery Protection
 - Load Separation (When Converter Off)

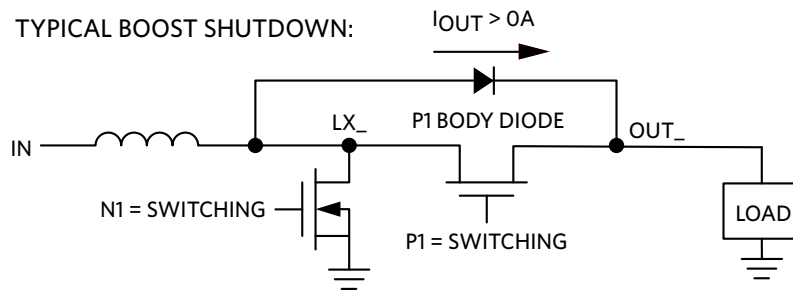

Figure 36. Typical Boost Converter in Shutdown

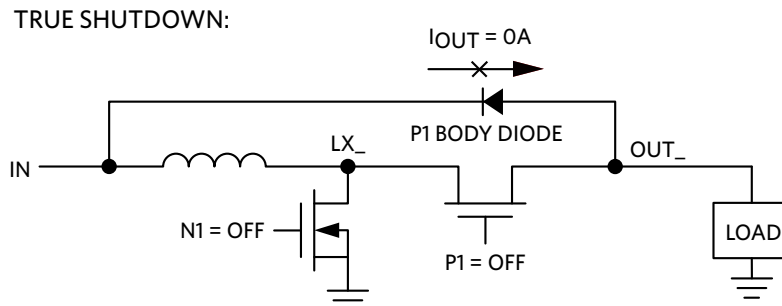

Figure 37. True Shutdown Boost Converter

High-Efficiency Buck-Boost Regulator

In many battery applications, it is necessary to regulate a system voltage that is within the voltage range of the battery. This becomes a challenge, since the battery voltage can be above or below the system voltage, depending on the battery's SOC. For these applications, it becomes essential to have a converter with both buck and boost functionality.

A common solution to this issue is the use of a buck-boost regulator to provide output voltage regulation. The **MAX77801** (Figure 38) utilizes a 4-switch H-bridge configuration to support both buck and boost operating modes using only a single inductor. The unique control algorithm allows high-efficiency, outstanding line-/load-transient response and seamlessly transitions between buck and boost modes. The MAX77801 also features a dynamic voltage scaling (DVS) logic input to switch between two pre-programmed voltages with programmable rising/falling slew-rate control. Altogether, these features are offered in either a small WLP or TQFN package.

Key Features of MAX77801

- Design Flexibility
 - Up to 2A of Output Current
 - Digitally Adjustable V_{OUT} (2.6V to 4.1875V, 12.5mV Steps)
 - High-Speed I²C Interface (Up to 3.4MHz)
- Extended Battery Life
 - 55µA Quiescent Current
 - Up to 97% Peak Efficiency
- Small Solution Size
 - 2.5MHz Switching Frequency
 - WLP and TQFN Packages
- Integrated Protection
 - POK Output
 - Soft-Start
 - True Shutdown
 - Thermal Shutdown
 - Short-Circuit Protection

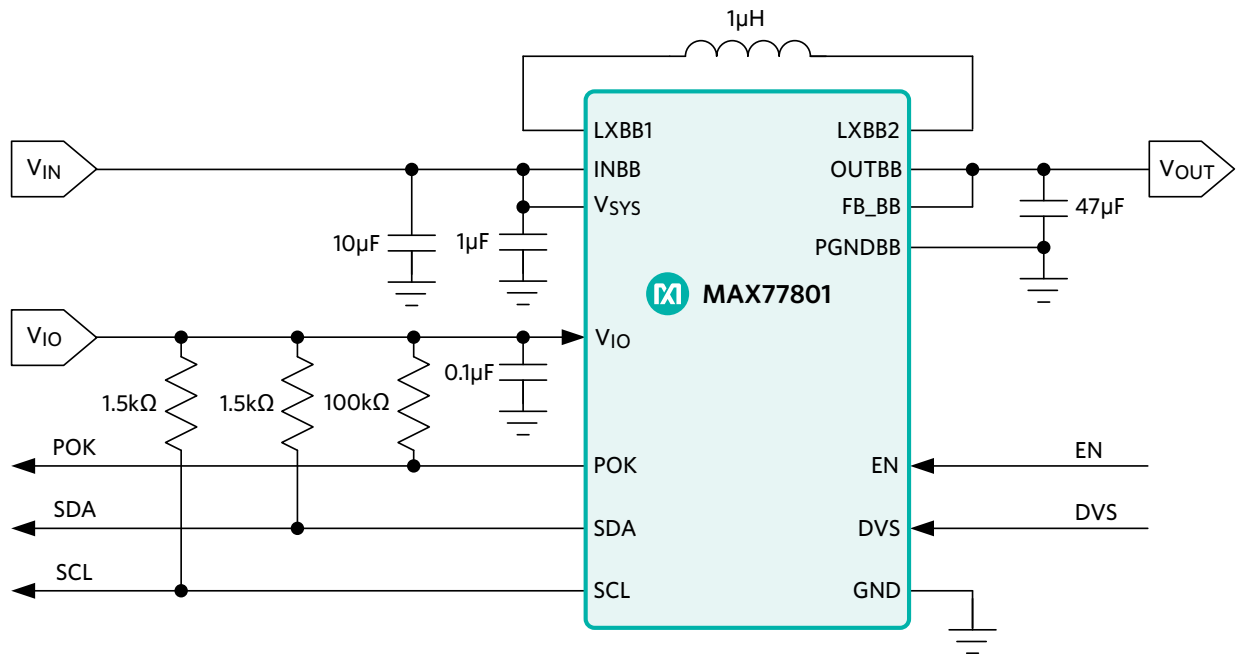

Figure 38. MAX77801 Typical Operating Circuit

Table 5. Buck Converter—Remote Sensing and Voltage Positioning Product Selector

Part Number	V _{IN} (min) (V)	V _{IN} (max) (V)	V _{OUT1} (min) (V)	V _{OUT1} (max) (V)	Preset V _{OUT} (V)	I _{OUT1} (max) (A)	Switch Type	Sync. Switch.	I _{CC} (max) (mA)	DC-DC Outputs	Oper. Freq. (kHz)	Package/ Pins	Smallest Available Package (max with pins) (mm ²)
REMOTE SENSING SOLUTIONS													
MAX8952	2.5	5.5	0.77	1.4		2.5	Internal	Yes	0.08	1	3250	WLP/16	4.5
MAX8649*	2.5	5.5	0.75	1.38	1.05, 1.23, 1.27	1.8	Internal	Yes	0.07	1	3250	WLP/16	4.5
MAX8973A*	2.6	4.5	0.6	1.4	1, 1.2	9	Internal	Yes	0.19	1	2000	WLP/28	6.6
VOLTAGE POSITIONING SOLUTIONS													
MAX1556_*	2.6	5.5	0.75	5.5	1.8, 2.5, 3.3	1.2	Internal	Yes	0.016	1	1000	TDFN-EP/10	9.6
MAX1557*	2.6	5.5	0.75	5.5	1, 1.3, 1.5	0.6	Internal	Yes	0.016	1	1000	TDFN-EP/10	9.6
MAX1733*	2.7	5.5	1.25	2		0.25	Internal	Yes	0.07	1	1200	SOT23/5	9
MAX8560	2.7	5.5	0.6	2.5		0.5	Internal	Yes	0.08	1	4000	TSOT/5	8.3
MAX8640Y*	2.7	5.5	0.8	2.5	1, 1.1, 1.2, 1.3, 1.5, 1.8, 2.5	0.5	Internal	Yes	0.048	1	2000	μDFN/6, SC70/6	1.6
MAX8640Z*	2.7	5.5	1.1	1.8	1.1, 1.2, 1.3, 1.5, 1.8	0.5	Internal	Yes	0.048	1	4000	μDFN/6, SC70/6	1.6
MAX77596*	3.5	24	1	10	3.3, 5	0.3	Internal	Yes	0.003	1	1700	TDFN/10	

Note: All parts listed in this table operate from -40°C to +85°C.

*Evaluation kit available.

Table 6. Boost Converter Product Selector

Part Number	V _{IN} (min) (V)	V _{IN} (max) (V)	V _{OUT1} (min) (V)	V _{OUT1} (max) (V)	Preset V _{OUT} (V)	I _{OUT1} (max) (A)	I _{CC} (max) (mA)	Shutdown Supply Current (typ) (μA)	DC-DC Outputs	Operating Frequency (kHz)	Package/Pins	Smallest Available Package (max with pins) (mm ²)
BOOST CONVERTER FOR VOLTAGE POSITIONING												
MAX8969*	2.5	5.5	3.3	5	3.3, 5	1	0.045	5	1	3000	WLP/9	1.7
BOOST CONVERTERS WITH TRUE SHUTDOWN												
MAX1606*	0.8	5.5	1.25	28		0.02	0.32	0.1	1	500	μMAX®/8	15.6
MAX1795*	0.7	5.5	2	5.5	3.3, 5	0.18	0.045	2	1		μMAX/8	15.6
MAX1947*	0.7	3.6	1.8	3.3	1.8, 1.9, 2.5, 2.7, 3, 3.3	0.25	0.11		1		TDFN-EP/8	9.6
MAX8570* MAX8571* MAX8574*	2.7	5.5	2.7	28	15	0.025	0.035	0.05	1		SOT23/6, μDFN/6	4.2
MAX8614*	2.7	5.5	3	24		0.125	0.8	0.1	2	1000	TDFN-EP/14	9.6
MAX8969*	2.5	5.5	3.3	5	3.3, 5	1	0.045	0.8	1	3000	WLP/9	1.7
MAX17220* MAX17221* MAX17222* MAX17223* MAX17224* MAX17225*	0.4	5.5	1.8	5		0.085, 0.2, 0.4	0.0006	0.001	1	2000	WLP/6, μDFN/6	1.23

Note: All parts listed in this table operate from -40°C to +85°C.

*Evaluation kit available.

Table 7. Buck-Boost Converter Product Selector

Part Number	V _{IN} (min) (V)	V _{IN} (max) (V)	V _{OUT1} (min) (V)	V _{OUT1} (max) (V)	Preset V _{OUT} (V)	I _{OUT1} (max) (A)	Output Adjust. Method	Power-Good Signal	I _{CC} (max) (mA)	DC-DC Outputs	Oper. Freq. (kHz)	Package/Pins	Smallest Available Package (max with pins) (mm ²)
BUCK-BOOST CONVERTER WITH TRUE SHUTDOWN													
MAX77801*	2.3	5.5	2.6	4.1875	3.3, 3.4	2	Preset	Yes	0.07	1	2500	WLP/20	3.89
BUCK-BOOST CONVERTERS													
MAX1701*	0.7	5.5	2.2	5.5		0.8	Resistor	Yes	0.11	1	400	QSOP/16	30.9
MAX1705*	0.7	5.5	2.5	5.5		0.8	Resistor	Yes	0.19	1	400	QSOP/16	30.9
MAX1706*	0.7	5.5	2.5	5.5		0.4	Resistor	Yes	0.19	1	400	QSOP/16	30.9
MAX1765*	1	5.5	1.25	5	1.25, 2.85	0.8	Resistor	No	0.2	1	1000	QSOP/16	30.9

Note: All parts listed in this table operate from -40°C to +85°C.

*Evaluation kit available.

LED Drivers

Mobile and handheld applications often incorporate LEDs for either backlighting, camera flash, or status indicators (*Figure 39*). Our LED drivers are optimized to achieve high efficiencies at a reduced system footprint for a variety of portable applications. LED drivers include switch-mode (inductor-based), charge-pump (capacitor-based), and linear topologies to deliver optimum performance for any application.

White LED (WLED) drivers provide high efficiency and brightness matching for backlighting in LCD displays. To control brightness, these drivers regulate LED currents. The LEDs may be arranged in either a serial and/or parallel configuration.

Traditionally, inductor-based LED drivers have been the best choice for efficiency and battery life. Since they require an inductor, careful layout and design is needed to avoid

electromagnetic and interference issues. High step-up ratios and efficiency are easily maintained over a wide range of input-to-output voltage ratios. Furthermore, higher output voltages allow for more LEDs in a series configuration.

Charge-pump solutions are simpler to implement, often smaller and with lower costs, since they rely only on small capacitors for voltage conversion. Charge-pump converters are typically only efficient when generating discrete multiples of their input voltages (e.g., 1.5x, 2x). However, newer charge-pump controllers have emerged to provide higher efficiencies for a wide range of input-to-output voltage ratios. Charge-pump solutions are generally used in the LED parallel configuration.

Linear current regulator solutions have the advantage of simplicity, small size, and low cost. They are much less efficient than the switching solutions, but provide tight current regulation to reduce brightness variation and avoid EMI concerns.

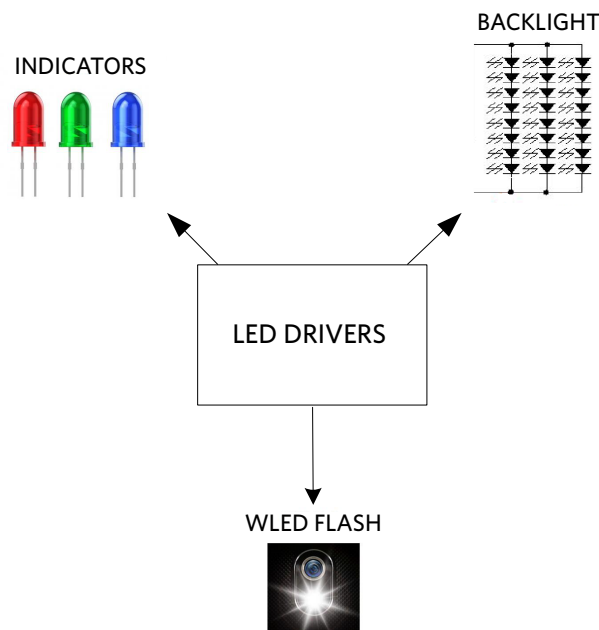

Figure 39. Typical LED Driver Applications

LED Driver Topologies

Inductor-Based (MAX1698/MAX1698A) (Figure 40)

- Many LEDs On One String
 - Large Output Voltage
- Supports Bright LEDs
 - High Output Current
- Superior Heavy Load Efficiency
- Wide Input Voltage Range
- Higher Cost
- Greater EMI
- Greater Design Complexity

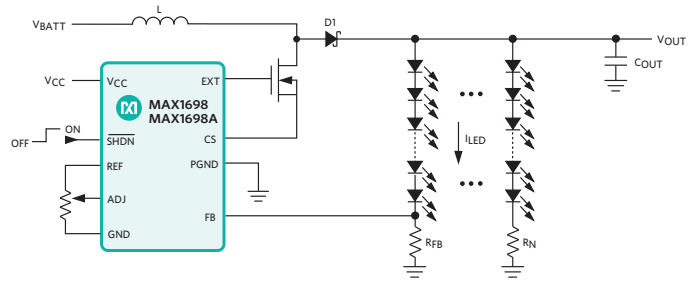

Figure 40. MAX1698/MAX1698A Inductor-Based LED Driver

Charge Pump (MAX8647/MAX8648) (Figure 41)

- Small Form-Factor
 - Few External Capacitors Required
- Superior Light-Load Efficiency
- Total LEDs in String Limited By Rated Output Current
- Exhibits EMI Due to Switching
- Optimum Efficiency Over a Narrow Range of Input Voltages
- Resistor Required for Each LED
 - Conduction Losses Reduce Efficiency

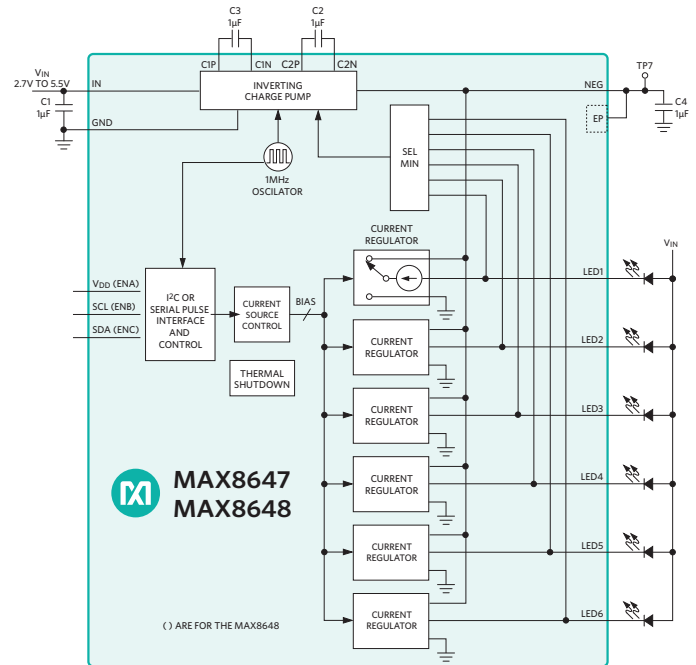

Figure 41. MAX8647/MAX8648 Charge-Pump LED Driver

Linear Control (MAX1916) (Figure 42)

- Controlled Current Source
 - $\pm 3\%$ Tight Current Regulation
 - Reduced Brightness Variation
- No EMI Concerns
- Total LEDs in String Limited by Input Voltage
- Low Efficiency

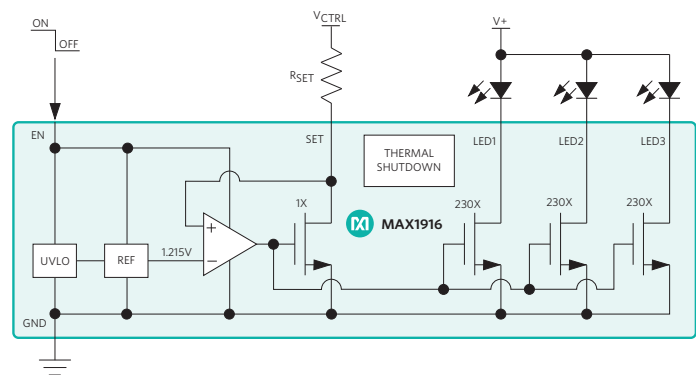

Figure 42. MAX1916 Linear LED Driver

Transmissive LCD LED Backlight Driver

Transmissive LCD technology requires an LED backlight to view graphics on the display when there is little to no external light available. Transmissive LCD displays are common to mobile devices that provide visual feedback to the user. Proper LED lighting control is required to regulate brightness with little variation and provide protection to the LED backlight string. Our LED drivers provide the protection and control required by LED backlight displays with high efficiencies and low I_Q for single-cell lithium battery operation. An example application is shown in *Figure 43* to demonstrate

the **MAX8901A** in a typical transmissive LCD backlight application. The MAX8901A provides up to 24.75mA and a maximum efficiency of 91%. The device operates with a 70 μ A quiescent current for minimal parasitic power draw from the battery. The low-power shutdown mode only requires 10nA of shutdown current and blocks current into the LEDs. Protection features include LED overvoltage protection, input undervoltage/overvoltage lockout, internal soft-start, and thermal shutdown. *Figure 43* illustrates LED dimming via a PWM input from a microcontroller.

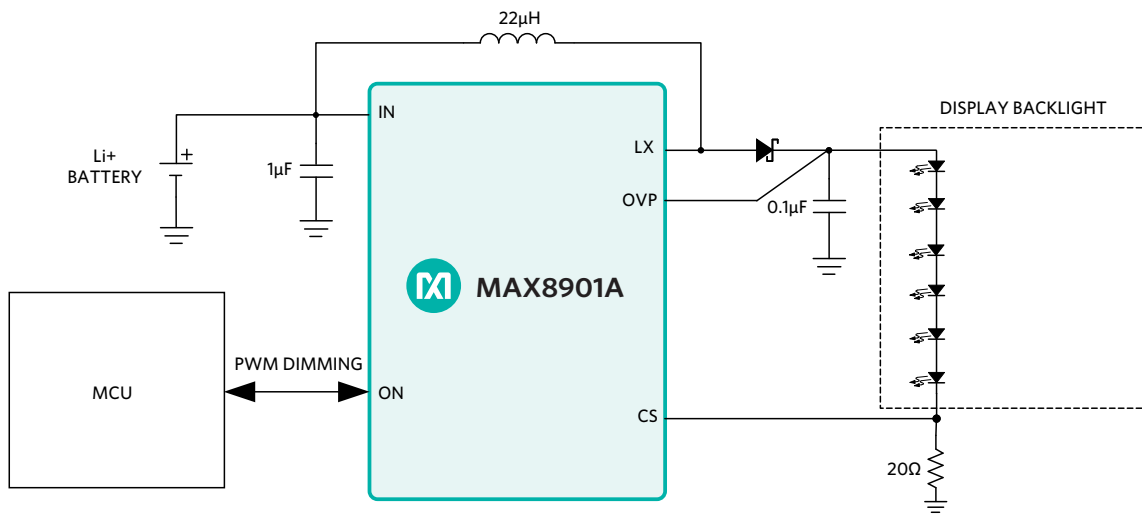

Figure 43. Transmissive LCD LED Backlight Using MAX8901A LED Driver

Single WLED Camera Flash Driver

Many of today’s mobile devices integrate cameras for photography, surveillance, documentation, imaging, and a variety of other applications. These devices operate in both light and dark environments; therefore, cameras must be able to illuminate dim or dark scenery. Digital cameras typically use WLEDs for illumination, due to their relatively small size and high light-conversion efficiency. The **MAX8607** (Figure 44) provides the high pulse current required by high-current WLEDs for camera flash applications. To allow versatility in camera lighting designs, the MAX8607 provides four modes of operation:

Flash Mode: Provides a 1.5A peak pulse current for driving WLEDs in camera flash applications.

Movie Mode: Provides a continuous 360mA current to provide a constant light source.

Disco Mode: Drives 80mA of continuous LED current, while maintaining the output voltage at a fixed 5V. Disco mode allows constant LED illumination with the ability to provide up to 1A current for auxiliary functions using the 5V rail.

Shutdown Mode: Reduces supply current to 0.1µA, which dramatically reduces power consumption to increase battery life.

Additional Features:

- Supports High-Power White LEDs
 - Flash Mode Current Up to 1.5A
 - 84% Efficiency at 1.1A
- Low-Power Shutdown (0.1µA)
- Small External Components
 - 1MHz PWM at All Loads
- Integrated Protection
 - LED Temperature Derating Thermal Protection
 - Output Under/Overvoltage Protection (2.38V/5.7V)
 - Soft-Start

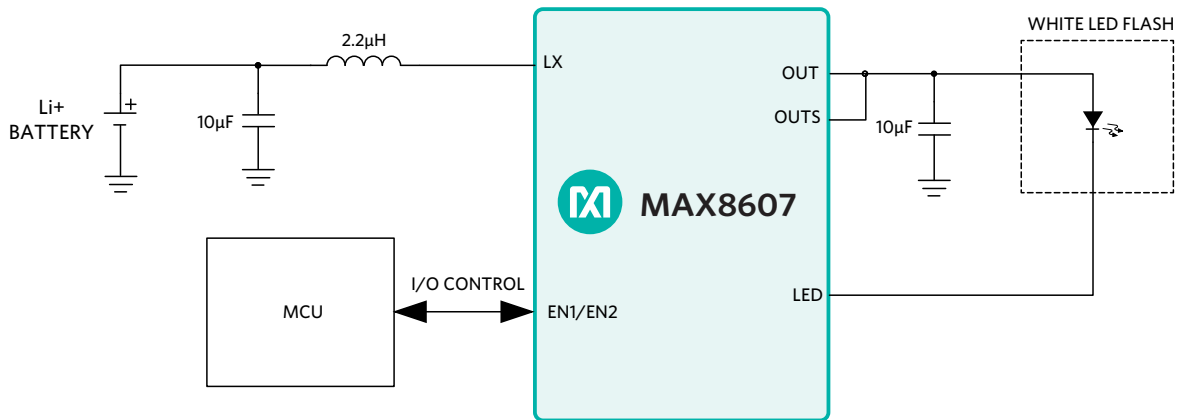

Figure 44. MAX8607 Typical Operating Circuit

LED Ambient Temperature Derating Protection

The final operating temperature for an LED is often not well known during the evaluation stage, and may vary considerably from one environment to another. Mobile devices operate in numerous environments, which requires designers to consider a range of temperatures and their impact on LED performance. Overheating may result in damage or a degraded LED lifetime; thus, care must be placed on the junction temperature of an LED to ensure reliability.

Figure 45 demonstrates the maximum allowable LED current vs. ambient temperature for LEDs with various junction-to-ambient thermal resistances. An LED with greater thermal resistance will have a greater rise in junction temperature for the same amount of dissipated power and ambient temperature; therefore, it will require derating at a lower ambient temperature. LED manufacturers typically provide a thermal derating curve like the one shown Figure 45 to ensure designers do not overheat the LED.

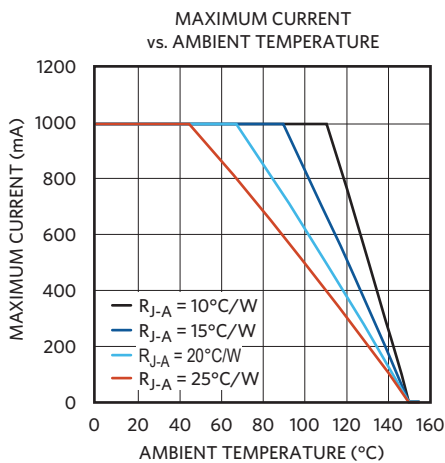

Figure 45. Example of LED Temperature Derating from LED Manufacturer

Thermal derating in our LED drivers extend LED lifetime by reducing LED current in proportion to an increase in junction temperature. It is especially critical to understand thermal derating in mobile systems, since end applications avoid forced cooling due to size constraints. The temperature derating function of select LED drivers allows LED current to be safely set higher at normal operating temperatures, thereby allowing either a brighter display or fewer LEDs to be used for normal display brightness. In addition, an exposed paddle provides thermal conduction between the die junction and PCB, which allows the die temperature to be very close to board temperature. This also allows the derating function to be based on the ambient system temperature.

Figure 46 demonstrates a comparison between the ambient temperature derating curve of the MAX8595 and MAX8596 without temperature derating. The designer must ensure that the temperature derating of the LED driver complies with the manufacturer’s specifications.

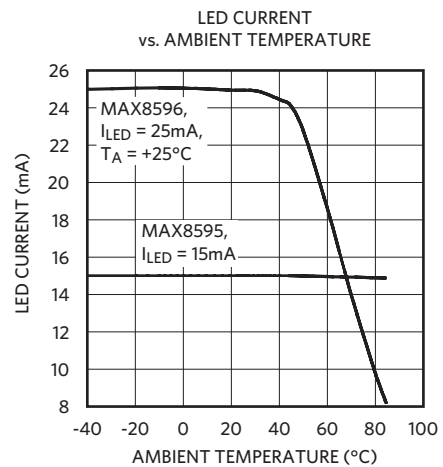

Figure 46. LED Temperature Derating Profile for MAX8595/MAX8596

Dual-Phase Step-Up Converter and LED Driver

Highly integrated mobile devices have a variety of features that place great demand on the device’s battery. A typical feature many mobile devices share is an integrated LED for either camera flash or torch-lighting applications. The bright LED flash requires a burst of battery current that may result in a battery undervoltage condition. To prevent such an event from occurring, the designer must account for all peak system loads and ensure they do not overload the battery.

The **MAX77387** dual-phase step-up converter (Figure 47) with integrated LED drivers has a variety of features to limit LED current under various system events. Dual Tx logic inputs are used to limit LED flash current during high-current events, such as a GSM or WCDMA transmission. Additionally, the device features MAXFLASH 2.0 technology, which adjusts LED current based on a user-defined input voltage threshold. Together these features provide increased protection to prevent a battery undervoltage condition. Furthermore, an I²C interface allows the user to dynamically adjust a host of control and protection features to allow system flexibility.

Key Features of MAX77387

- Extended Battery Life
 - Adaptive Output Voltage Regulation
 - Over 90% Peak Efficiency
 - Skip Mode for Light Loads
 - True Shutdown
- I²C Programmable
 - Output Current
 - Safety Timer
 - Ramp-Up/Down Rate
 - High-Speed I²C Interface (Up to 3.4MHz)
- Small Solution Size
 - 4MHz Switching Frequency Per Phase
 - Small 0.47µH Inductor Per Phase
 - 2.1mm x 1.73mm WLP Package
- Integrated Protection
 - NTC Monitoring for LED Temperature
 - Overvoltage Protection
 - Thermal Shutdown
 - Open/Short LED Detection

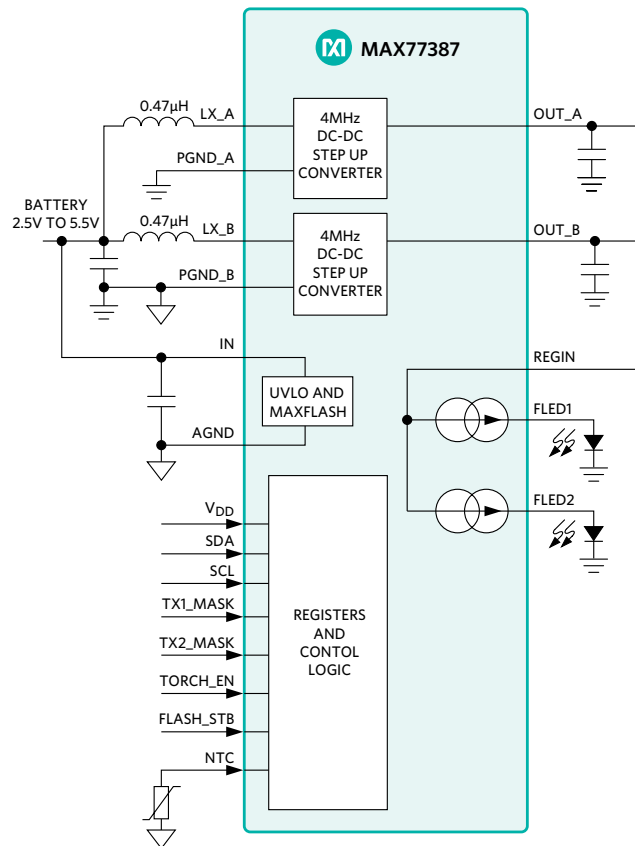

Figure 47. MAX77387 Typical Operating Circuit

Table 8. LED Driver Product Selector

Part Number	Regulation Topology	LED Configuration (MAX LEDs/ LED Channels)	I _{LED} per Channel (max) (A)	Dimming Ratio (max)	Dimming Control	P _{OUT} (W)	V _{IN} Range (V)	I _{CC} (max) (mA)	LED String Voltage (max) (V)	Oper. Freq. (kHz)	Package/Pins	Smallest Available Package (max with pins) (mm ²)
TEMPERATURE DERATING LED DRIVERS												
MAX1579*	Inductor-based	Series (8 LEDs, 1 Ch.)	0.025		Analog, PWM	0.9	2.7 to 5.5	5	32	1000	TQFN/24	16.8
MAX8596_*	Inductor-based	Series (9 LEDs, 1 Ch.)	0.025		Analog, PWM	1	2.6 to 6	0.7	32	1000	TDFN-EP/8	9.6
MAX8607*	Inductor-based, linear	Parallel (1 LED, 1 Ch.)	1.5		Digital	6	2.7 to 5.5	4	5.5	1000	TDFN-EP/14	9.6
MAX8647*	Charge pump	Parallel (6 LEDs/6 Ch.)	0.024	240	I ² C serial	0.6	2.7 to 5.5	0.1	5	1000	TQFN/16	9.6
MAX8648*	Charge pump	Parallel (6 LEDs/6 Ch.)	0.024	240	Serial pulse	0.6	2.7 to 5.5	0.2	5	1000	TQFN/16	9.6
MAX8821*	Charge pump	Parallel (6 LEDs/6 Ch.)	0.025	256	I ² C serial	0.6	2.7 to 5.5	0.12	5.5	1000	TQFN/28	16.8
LED DRIVERS												
MAX1554*	Inductor-based	Series (10 LEDs, 1 Ch.)	0.02	10	Analog, PWM	0.8	2.7 to 5.5	0.65	40	250	TDFN-EP/8	9.6
MAX1561*	Inductor-based	Series (6 LEDs, 1 Ch.)	0.02		Analog, PWM	0.9	2.6 to 5.5	0.55	26	1000	TDFN-EP/8	9.6
MAX1599	Inductor-based	Series (6 LEDs, 1 Ch.)	0.02		Analog, PWM	0.9	2.6 to 5.5	0.55	26	500	TDFN-EP/8	9.6
MAX1698*	Inductor-based	Series-parallel (50 LEDs, 4 Ch.)	0.35	20	Analog	5	2.7 to 5.5	0.5	60	300	μMAX/10	15.4
MAX8595*	Inductor-based	Series (9 LEDs, 1 Ch.)	0.025		Analog, PWM	1	2.6 to 6	0.7	32	1000	TDFN-EP/8	9.6
MAX8901A*	Inductor-based	Series (6 LEDs, 1 Ch.)	0.025		PWM, serial pulse	0.6	2.6 to 5.5	0.135	24	750	See the MAX8901A data sheet	

Note: All parts listed in this table operate from -40°C to +85°C.

*Evaluation kit available.

List of Figures

Figure 1. Typical CPU Power Rails Provided by a PMIC	3
Figure 2. Smartphone Block Diagram Using MAX8660 PMIC.....	4
Figure 3. Tethered Bluetooth Headset Application Using the MAX77650 SIMO	5
Figure 4. Untethered Bluetooth Headset Application Using MAX77650 SIMO	6
Figure 5. MAX8662 Typical Operating Circuit.....	7
Figure 6. Portable Music Player Application Using MAX8662 PMIC.....	8
Figure 7. Power Path When $I_{LOAD} > I_{DC}$	9
Figure 8. Power Path When $I_{LOAD} < I_{DC}$	9
Figure 9. Power Path With Battery, But No External Supply	9
Figure 10. Power Path With External Supply, But No Battery	9
Figure 11. Li+ Battery Charging and Fuel Gauging.....	11
Figure 12. Charging Stages for Safe Charging.....	11
Figure 13. Typical Handheld Gaming System Using MAX8971 Battery Charger	12
Figure 14. Wireless Sensor Node Using MAX8814 Linear Battery Charger.....	13
Figure 15. Digital Camera Application Using the MAX8903 Switch-Mode Charger.....	13
Figure 16. MAX77818 Typical Operating Circuit	14
Figure 17. Wireless Speaker Application Using MAX77818 Battery Charger and Fuel Gauge	15
Figure 18. MAX17055 Fuel Gauge in a Battery Pack System.....	18
Figure 19. MAX17055 Fuel Gauge in a Captive Battery System	18
Figure 20. Counterfeit Battery Prevention Using Authentication.....	19
Figure 21. Authentication Procedure Block Diagram	20
Figure 22. Battery Pack Authentication Using the MAX17201 Fuel Gauge	20
Figure 23. MAX17048 Fuel Gauge in Hibernate Mode.....	21
Figure 24. MAX17048 Fuel Gauge in Active Mode	21
Figure 25. MAX17215 Multi-Cell Fuel Gauge for Robot/Drone Applications	22
Figure 26. Typical DC-DC Converters for Battery-Powered Applications.....	24
Figure 27. Buck Converter with Ground Impedance Affects Feedback Signal	25
Figure 28. MAX8649/MAX8649A with Differential Feedback to Bypass GND Impedance.....	25
Figure 29. Proper Kelvin Sense Connections	25
Figure 30. Load Step Without Voltage Positioning	26
Figure 31. Load Step with Voltage Positioning	26
Figure 32. MAX1556/MAX1556A Typical Operating Circuit.....	26

List of Figures (continued)

Figure 33. MAX1556 Voltage Positioning Load Line.....	26
Figure 34. MAX77596 Wide V_{IN} Buck Converter for USB Type-C Port Controller.....	27
Figure 35. MAX8969 Auto-Track Boost Converter Typical Application Circuit	28
Figure 36. Typical Boost Converter in Shutdown.....	29
Figure 37. True Shutdown Boost Converter.....	29
Figure 38. MAX77801 Typical Operating Circuit	30
Figure 39. Typical LED Driver Applications	33
Figure 40. MAX1698/MAX1698A Inductor-Based LED Driver.....	34
Figure 41. MAX8647/MAX8648 Charge-Pump LED Driver.....	34
Figure 42. MAX1916 Linear LED Driver	34
Figure 43. Transmissive LCD LED Backlight Using MAX8901A LED Driver	35
Figure 44. MAX8607 Typical Operating Circuit	36
Figure 45. Example of LED Temperature Derating from LED Manufacturer	37
Figure 46. LED Temperature Derating Profile for MAX8595/MAX8596.....	37
Figure 47. MAX77387 Typical Operating Circuit	38

Related Resources

- Power Management ICs
Power Management IC Products
 - [Note 3174: Selecting Power Management for Cellular Handsets](#)
- Battery Chargers and Fuel Gauges
Battery Management Products
 - [Tutorial 913: Switch-Mode, Linear, and Pulse Charging Techniques for Li+ Battery in Mobile Phones and PDAs](#)
 - [Application Note 4169: Understanding Li+ Battery Operation Lessens Charging Safety Concerns](#)
 - [Tutorial 4803: The Basics of USB Battery Charging – A Survival Guide](#)
 - [Application Note 4572: Reverse Battery Charger Protection](#)
 - [Tutorial 680: How to Design Battery Charger Applications that Require External Microcontrollers and Related System-Level Issues](#)
- Battery Fuel Gauge Technology
ModelGauge Battery Fuel Gauge Technology
 - [Application Note 5779: Introduction to SHA-256 Master/Slave Authentication](#)
- DC-DC Converters
Switching Regulator Products
 - [Tutorial 2031: DC-DC Converter Tutorial](#)
 - [Application Note 3767: Meeting the Challenges of Power-Supply Design for Modern, High-Current CPUs](#)
 - [Application Note 3177: Powering High-Performance ASICs and Microprocessors](#)**EE-Sim Design and Simulation Tool**
- LED Drivers
LED Driver Products
 - [Application Note 3070: Standard and White LED Basics and Operation](#)
 - [Reference Schematic 1804: Driving LEDs in Battery-Operated Applications – Controlling Brightness Power Efficiently](#)
 - [Application Note 3243: White-LED Boost Converter vs. Charge Pump](#)

Trademarks

Bluetooth is a registered trademark by Bluetooth SIG, Inc.

Wi-Fi is a registered certification mark of Wi-Fi Alliance Corporation.

ModelGauge, Smart Power Selector, True Shutdown are trademarks and EE-Sim, 1-Wire, μ MAX are registered trademarks of Maxim Integrated Products, Inc.

Learn more

For more information, visit:

www.maximintegrated.com/mobilepower

Rev 0; October 2017